

1.25Gbps SFP Optical Transceiver, 40km Reach EP-3124- L4x(D)

Features

- ◆ Data-rate of 1.25Gbps operation
- ◆ 1310nm DFB laser and PIN photodetector for 40km transmission
- ◆ Compliant with SFP MSA and SFF-8472 with duplex LC receptacle
- ◆ Digital Diagnostic Monitoring:
Internal Calibration or External Calibration
- ◆ Compatible with SONET OC-24-LR-1
- ◆ Compatible with RoHS
- ◆ +3.3V single power supply
- ◆ Operating case temperature:
Standard : 0 to +70°C
Industrial : -40 to +85°C



Applications

- ◆ Gigabit Ethernet
- ◆ Fiber Channel
- ◆ Switch to Switch interface
- ◆ Switched backplane applications
- ◆ Router/Server interface
- ◆ Other optical transmission systems

Description

The SFP transceivers are high performance, cost effective modules supporting data-rate of 1.25Gbps and 40km transmission distance with SMF.

The transceiver consists of three sections: a DFB laser transmitter, a PIN photodiode integrated with a trans-impedance preamplifier (TIA) and MCU control unit. All modules satisfy class I laser safety requirements.

The transceivers are compatible with SFP Multi-Source Agreement (MSA) and SFF-8472. For further information, please refer to SFP MSA.

Module Block Diagram

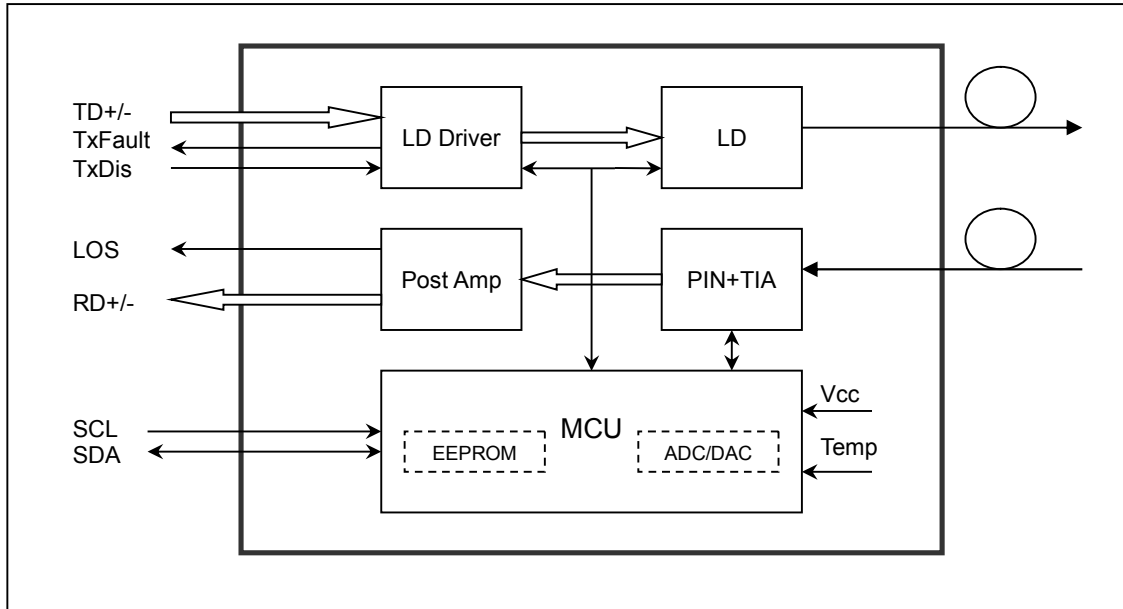

Absolute Maximum Ratings

Table 1 - Absolute Maximum Ratings

| Parameter | Symbol | Min | Max | Unit |
|---------------------|--------|------|-----|------|
| Supply Voltage | Vcc | -0.5 | 4.5 | V |
| Storage Temperature | Ts | -40 | +85 | °C |
| Operating Humidity | - | 5 | 85 | % |

Recommended Operating Conditions

Table 2 - Recommended Operating Conditions

| Parameter | Symbol | Min | Typical | Max | Unit |
|----------------------------|------------|------|---------|------|------|
| Operating Case Temperature | Standard | 0 | | +70 | °C |
| | Industrial | -40 | | +85 | °C |
| Power Supply Voltage | Vcc | 3.13 | 3.3 | 3.47 | V |
| Power Supply Current | Icc | | | 300 | mA |
| Data Rate | | | 1.25 | | Gbps |

Optical and Electrical Characteristics

Table 3 - Optical and Electrical Characteristics

| Parameter | Symbol | Min | Typical | Max | Unit | Notes |
|----------------------------------|--------------------------------|------|---------|-----------------|----------|-------|
| Transmitter | | | | | | |
| Centre Wavelength | λ_c | 1260 | 1310 | 1360 | nm | |
| Spectral Width (-20dB) | $\Delta\lambda$ | | | 1 | nm | |
| Side Mode Suppression Ratio | SMSR | 30 | | | dB | |
| Average Output Power | P _{out} | -5 | | 0 | dBm | 1 |
| Extinction Ratio | ER | 9 | | | dB | |
| Optical Rise/Fall Time (20%~80%) | t _r /t _f | | | 0.26 | ns | |
| Data Input Swing Differential | V _{IN} | 400 | | 1800 | mV | 2 |
| Input Differential Impedance | Z _{IN} | 90 | 100 | 110 | Ω | |
| TX Disable | Disable | 2.0 | | V _{cc} | V | |
| | Enable | 0 | | 0.8 | V | |
| TX Fault | Fault | 2.0 | | V _{cc} | V | |
| | Normal | 0 | | 0.8 | V | |
| Receiver | | | | | | |
| Centre Wavelength | λ_c | 1260 | | 1580 | nm | |
| Receiver Sensitivity | | | | -23 | dBm | 3 |
| Receiver Overload | | -3 | | | dBm | 3 |
| LOS De-Assert | LOS _D | | | -24 | dBm | |
| LOS Assert | LOS _A | -35 | | | dBm | |
| LOS Hysteresis | | 1 | | 4 | dB | |
| Data Output Swing Differential | V _{out} | 400 | | 1800 | mV | 4 |
| LOS | High | 2.0 | | V _{cc} | V | |
| | Low | | | 0.8 | V | |

Notes:

1. The optical power is launched into SMF.
2. PECL input, internally AC-coupled and terminated.
3. Measured with a PRBS 2⁷-1 test pattern @1250Mbps, BER $\leq 1 \times 10^{-12}$.
4. Internally AC-coupled.

Timing and Electrical

Table 4 - Timing and Electrical

| Parameter | Symbol | Min | Typical | Max | Unit |
|---|----------------|-----|---------|-----------------|------|
| Tx Disable Negate Time | t_on | | | 1 | ms |
| Tx Disable Assert Time | t_off | | | 10 | μs |
| Time To Initialize, including Reset of Tx Fault | t_init | | | 300 | ms |
| Tx Fault Assert Time | t_fault | | | 100 | μs |
| Tx Disable To Reset | t_reset | 10 | | | μs |
| LOS Assert Time | t_loss_on | | | 100 | μs |
| LOS De-assert Time | t_loss_off | | | 100 | μs |
| Serial ID Clock Rate | f_serial_clock | | | 400 | KHz |
| MOD_DEF (0:2)-High | V _H | 2 | | V _{cc} | V |
| MOD_DEF (0:2)-Low | V _L | | | 0.8 | V |

Diagnostics

Table 5 – Diagnostics Specification

| Parameter | Range | Unit | Accuracy | Calibration |
|--------------|------------|------|----------|---------------------|
| Temperature | 0 to +70 | °C | ±3°C | Internal / External |
| | -40 to +85 | | | |
| Voltage | 3.0 to 3.6 | V | ±3% | Internal / External |
| Bias Current | 0 to 100 | mA | ±10% | Internal / External |
| TX Power | -5 to 0 | dBm | ±3dB | Internal / External |
| RX Power | -23 to -3 | dBm | ±3dB | Internal / External |

Digital Diagnostic Memory Map

The transceivers provide serial ID memory contents and diagnostic information about the present operating conditions by the 2-wire serial interface (SCL, SDA).

The diagnostic information with internal calibration or external calibration all are implemented, including received power monitoring, transmitted power monitoring, bias current monitoring, supply voltage monitoring and temperature monitoring.

The digital diagnostic memory map specific data field defines as following.

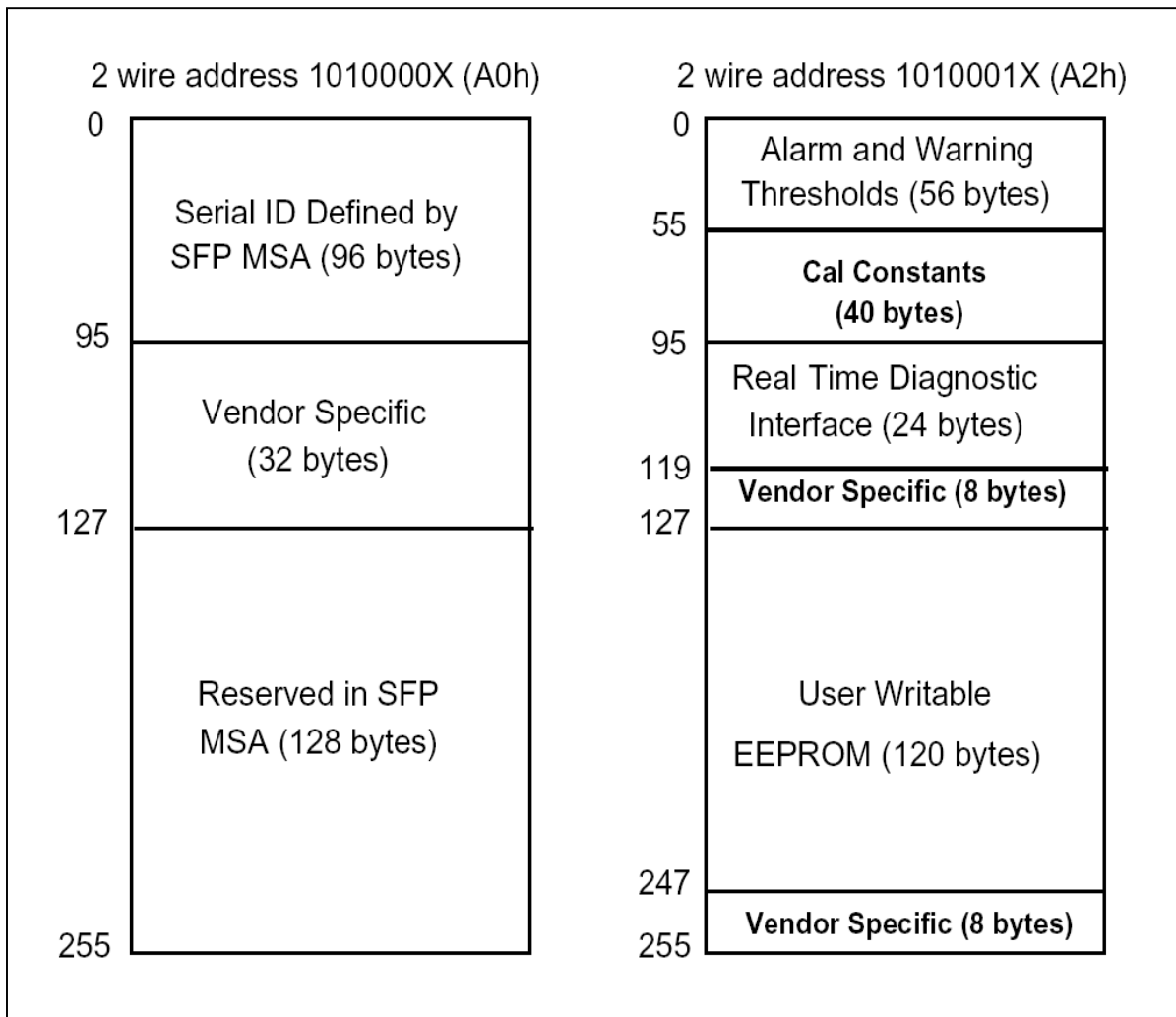

Pin Definitions

Pin Diagram

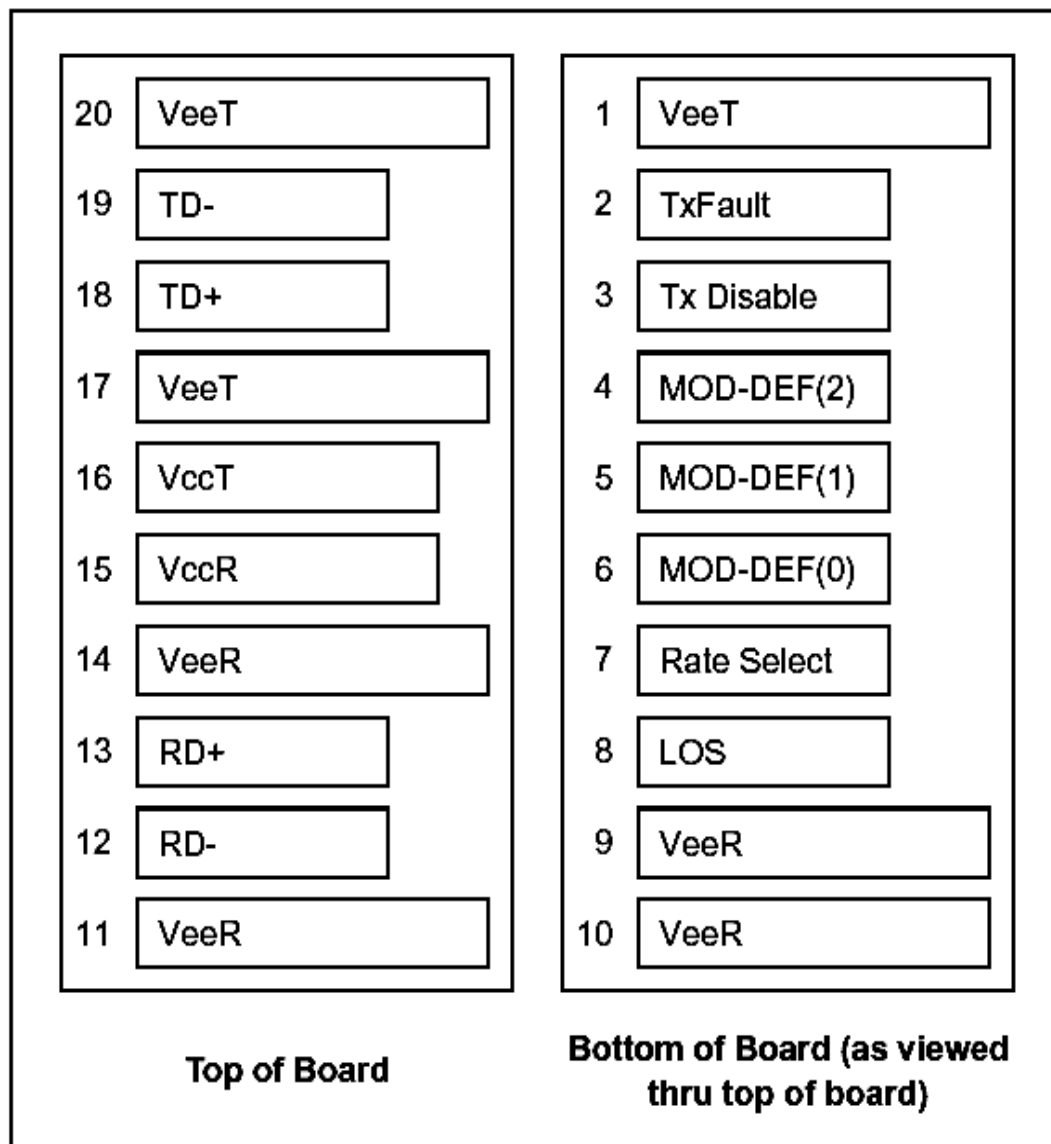

Pin Descriptions

| Pin | Signal Name | Description | Plug Seq. | Notes |
|-----|------------------|------------------------------|-----------|--------|
| 1 | V _{EET} | Transmitter Ground | 1 | |
| 2 | TX FAULT | Transmitter Fault Indication | 3 | Note 1 |
| 3 | TX DISABLE | Transmitter Disable | 3 | Note 2 |
| 4 | MOD_DEF(2) | SDA Serial Data Signal | 3 | Note 3 |
| 5 | MOD_DEF(1) | SCL Serial Clock Signal | 3 | Note 3 |
| 6 | MOD_DEF(0) | TTL Low | 3 | Note 3 |
| 7 | Rate Select | Not Connected | 3 | |
| 8 | LOS | Loss of Signal | 3 | Note 4 |
| 9 | V _{EER} | Receiver ground | 1 | |
| 10 | V _{EER} | Receiver ground | 1 | |
| 11 | V _{EER} | Receiver ground | 1 | |
| 12 | RD- | Inv. Received Data Out | 3 | Note 5 |
| 13 | RD+ | Received Data Out | 3 | Note 5 |
| 14 | V _{EER} | Receiver ground | 1 | |
| 15 | V _{CCR} | Receiver Power Supply | 2 | |
| 16 | V _{CCT} | Transmitter Power Supply | 2 | |
| 17 | V _{EET} | Transmitter Ground | 1 | |
| 18 | TD+ | Transmit Data In | 3 | Note 6 |
| 19 | TD- | Inv. Transmit Data In | 3 | Note 6 |
| 20 | V _{EET} | Transmitter Ground | 1 | |

Notes:

Plug Seq.: Pin engagement sequence during hot plugging.

- TX Fault is an open collector output, which should be pulled up with a 4.7k~10kΩ resistor on the host board to a voltage between 2.0V and V_{cc}+0.3V. Logic 0 indicates normal operation; Logic 1 indicates a laser fault of some kind. In the low state, the output will be pulled to less than 0.8V.
- TX Disable is an input that is used to shut down the transmitter optical output. It is pulled up within the module with a 4.7k~10kΩ resistor. Its states are:

| | |
|-----------------------|----------------------|
| Low (0 to 0.8V): | Transmitter on |
| (>0.8V, < 2.0V): | Undefined |
| High (2.0 to 3.465V): | Transmitter Disabled |
| Open: | Transmitter Disabled |
- Mod-Def 0,1,2. These are the module definition pins. They should be pulled up with a 4.7k~10kΩ resistor on the host board. The pull-up voltage shall be V_{ccT} or V_{ccR}.
 Mod-Def 0 is grounded by the module to indicate that the module is present
 Mod-Def 1 is the clock line of two wire serial interface for serial ID
 Mod-Def 2 is the data line of two wire serial interface for serial ID
- LOS is an open collector output, which should be pulled up with a 4.7k~10kΩ resistor. Pull up voltage between 2.0V and V_{cc}+0.3V. Logic 1 indicates loss of signal; Logic 0 indicates normal operation. In the low state, the output will be pulled to less than 0.8V.
- RD-/+ : These are the differential receiver outputs. They are internally AC-coupled 100 differential lines which should be terminated with 100Ω (differential) at the user SERDES.
- TD-/+ : These are the differential transmitter inputs. They are internally AC-coupled, differential lines with 100Ω differential termination inside the module.

Recommended Interface Circuit

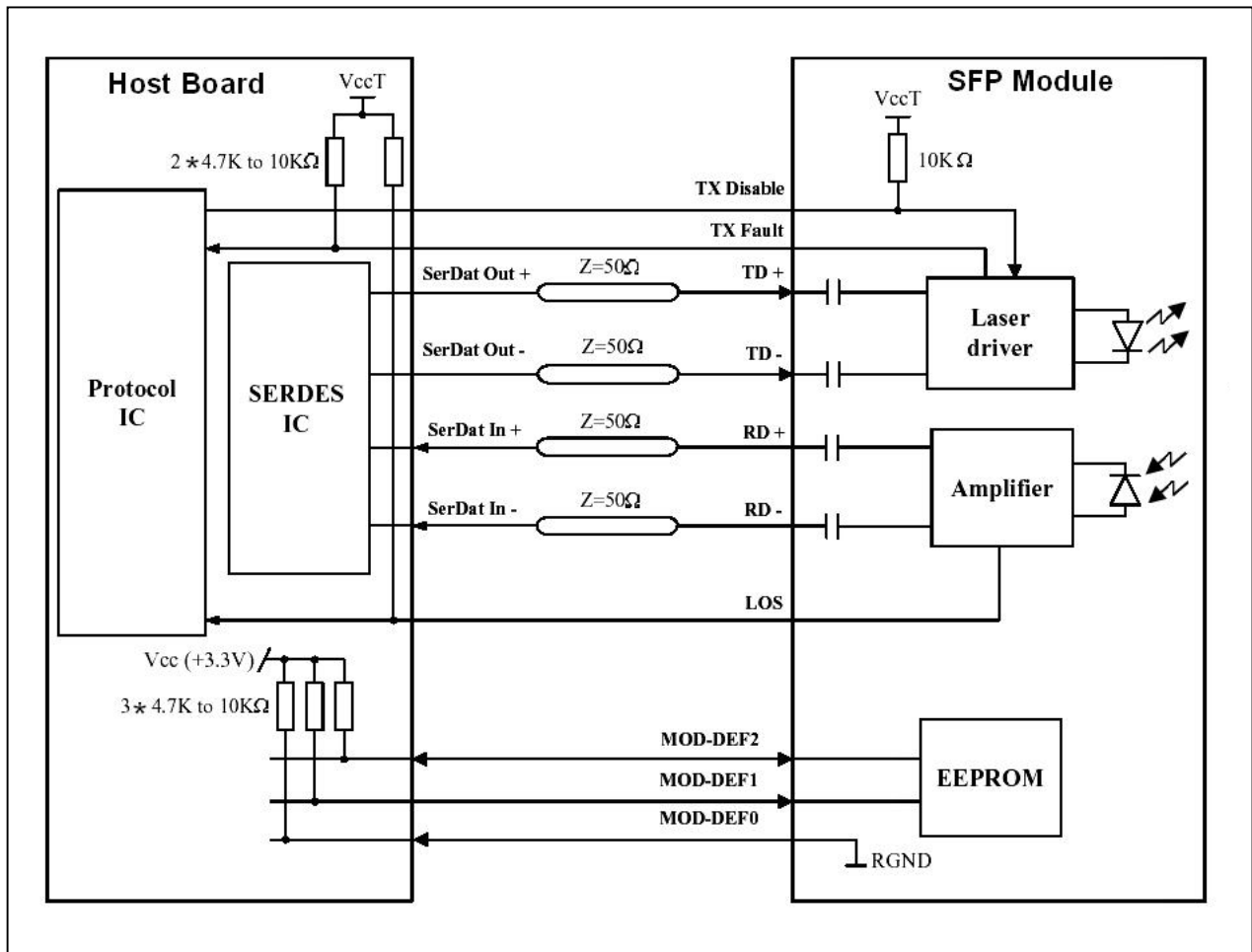

Mechanical Dimensions

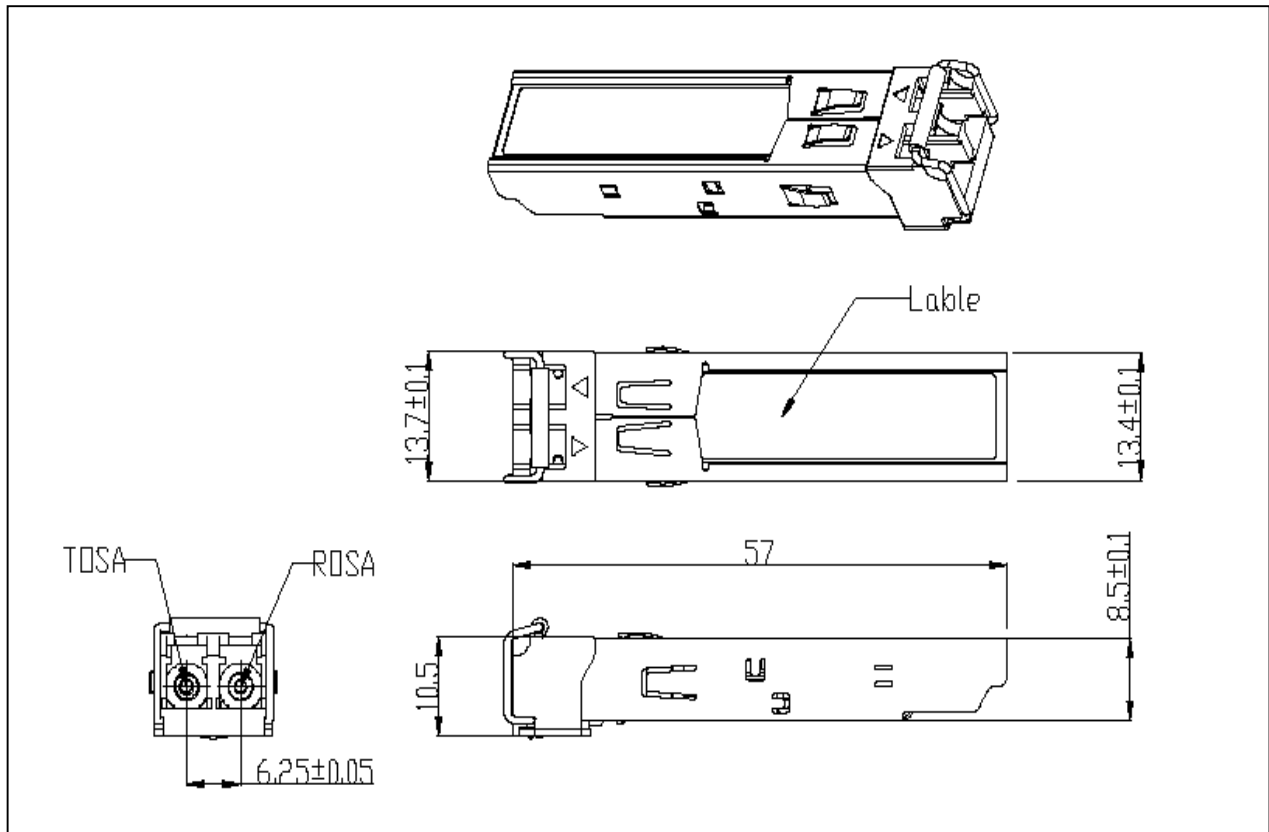

Regulatory Compliance

Empowerfiber SFP transceiver is designed to be Class I Laser safety compliant and is certified per the following standards

| Feature | Agency | Standard | Certificate / Comments |
|--------------------------|--------|---|------------------------|
| Laser Safety | FDA | CDRH 21 CFR 1040 and Laser Notice No. 50 | 1120295-000 |
| Product Safety | BST | EN 60825-1: 2007 EN 60825-2: 2004 EN 60950-1: 2006 | BT0905142001 |
| Environmental protection | SGS | RoHS Directive 2002/95/EC | GZ0902007478/CHEM |
| EMC | CCIC | EN 55022: 2006+A1: 2007 EN 55024: 1998+A1: 2001+A2: 2003 | CTE09020023 |

Important Notice

Performance figures, data and any illustrative material provided in this data sheet are typical and must be specifically confirmed in writing by empowerfiber before they become applicable to any particular order or contract. In accordance with the empowerfiber policy of continuous improvement specifications may change without notice.

The publication of information in this data sheet does not imply freedom from patent or other protective rights of empowerfiber or others. Further details are available from any empowerfiber sales representative.

E-mail: sales@Empowerfiber.com

Web : <http://www.Empowerfiber.com>