

## 155Mbps CWDM SFP Optical Transceiver, 120km Reach EPC-xx03-12CD

### Features

- ◆ Data-rate of 155Mbps operation
- ◆ 9 CWDM DFB wavelengths laser and PIN photodetector for 120km transmission
- ◆ Compliant with SFP MSA and SFF-8472 with duplex LC receptacle
- ◆ Digital Diagnostic Monitoring:  
Internal Calibration or External Calibration
- ◆ Compatible with RoHS
- ◆ +3.3V single power supply
- ◆ Operating case temperature:  
Standard : 0 to +70°C

### Applications

- ◆ Gigabit Ethernet
- ◆ Fiber Channel
- ◆ Switch to Switch interface
- ◆ Switched backplane applications
- ◆ Router/Server interface
- ◆ Other optical transmission systems

### Description

The SFP transceivers are high performance, cost effective modules supporting data-rate of 155Mbps and 120km transmission distance with SMF.

The transceiver consists of three sections: an uncooled CWDM DFB laser transmitter, a PIN photodiode integrated with a trans-impedance preamplifier (TIA) and MCU control unit. All modules satisfy class I laser safety requirements.

The transceivers are compatible with SFP Multi-Source Agreement (MSA) and SFF-8472. For further information, please refer to SFP MSA.



### Module Block Diagram

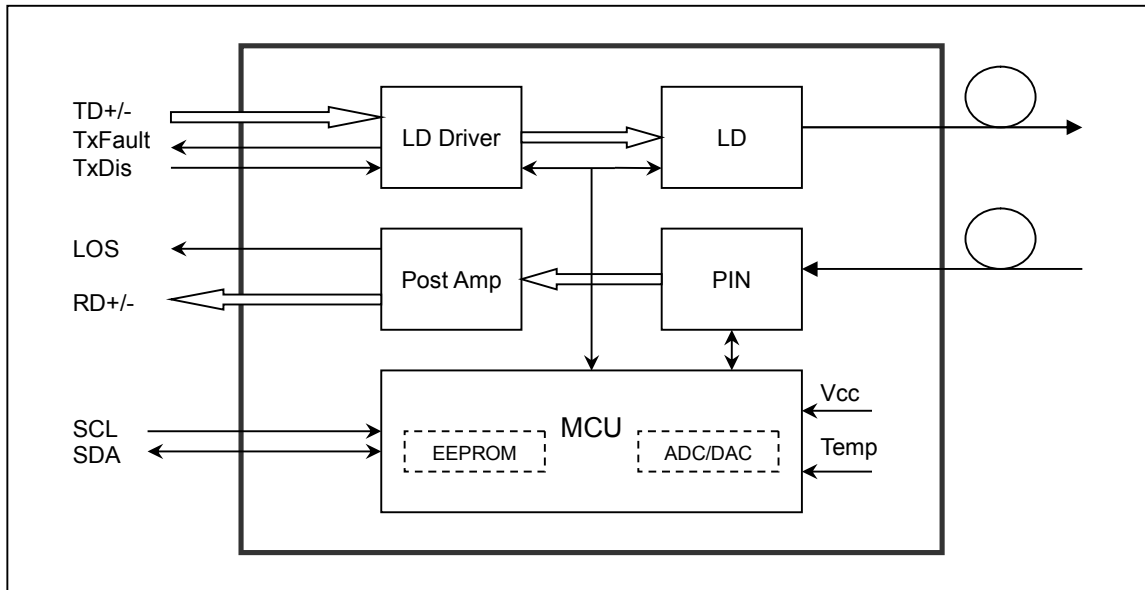

### Absolute Maximum Ratings

**Table 1 - Absolute Maximum Ratings**

| Parameter           | Symbol | Min  | Max | Unit |
|---------------------|--------|------|-----|------|
| Supply Voltage      | Vcc    | -0.5 | 4.5 | V    |
| Storage Temperature | Ts     | -40  | +85 | °C   |
| Operating Humidity  | -      | 5    | 95  | %    |

### Recommended Operating Conditions

**Table 2 - Recommended Operating Conditions**

| Parameter                  | Symbol | Min  | Typical | Max  | Unit |
|----------------------------|--------|------|---------|------|------|
| Operating Case Temperature | Tc     | 0    |         | +70  | °C   |
| Power Supply Voltage       | Vcc    | 3.13 | 3.3     | 3.47 | V    |
| Power Supply Current       | Icc    |      |         | 300  | mA   |

Data Rate

155

Mbps

**EPC-xx03-12CD**

 See table3 below for “xx” values Table3 - $\lambda$ C Wavelength Guide

| $\lambda$ C Wavelength Guide |             |      |      |             |      |
|------------------------------|-------------|------|------|-------------|------|
| Code                         | $\lambda$ C | Unit | Code | $\lambda$ C | Unit |
| 45                           | 1450        | nm   | 55   | 1550        | nm   |
| 47                           | 1470        | nm   | 57   | 1570        | nm   |
| 49                           | 1490        | nm   | 59   | 1590        | nm   |
| 51                           | 1510        | nm   | 61   | 1610        | nm   |
| 53                           | 1530        | nm   |      |             |      |

**Optical and Electrical Characteristics**
**EPC-xx03-12CD: (CWDM and PIN, 120km Reach)**
**Table 4 - Optical and Electrical Characteristics**

| Parameter                        | Symbol  | Min             | Typical     | Max             | Unit     | Notes |
|----------------------------------|---|-----------------|-------------|-----------------|----------|-------|
| <b>Transmitter</b>               |   |                 |             |                 |          |       |
| Centre Wavelength                | $\lambda$ C                                     | $\lambda$ C-6.5 | $\lambda$ C | $\lambda$ C+6.5 | nm       |       |
| Spectral Width (-20dB)           | $\Delta\lambda$                                 |                 |             | 1               | nm       |       |
| Side Mode Suppression Ratio      | SMSR  | 30              |             |                 | dB       |       |
| Average Output Power             | P <sub>out</sub>                                | 0               |             | 5               | dBm      | 1     |
| Extinction Ratio                 | ER  | 10              |             |                 | dB       |       |
| Jitter Generation (RMS)          |   |                 |             | 0.01            | UI       |       |
| Jitter Generation (PK-PK)        |   |                 |             | 0.1             | UI       |       |
| Output Optical Eye               | Compliant Telcordia GR-253-CORE and ITU-T G.957 |                 |             |                 |          |       |
| Optical Rise/Fall Time (20%~80%) | tr/ta   |                 |             | 0.26            | ns       |       |
| Data Input Swing Differential    | V <sub>IN</sub>                                 | 300             |             | 1860            | mV       | 2     |
| Input Differential Impedance     | Z <sub>IN</sub>                                 | 90              | 100         | 110             | $\Omega$ |       |
| TX Disable                       | Disable   | 2.0             |             | V <sub>cc</sub> | V        |       |
|                                  | Enable  | 0               |             | 0.8             | V        |       |
| TX Fault                         | Fault   | 2.0             |             | V <sub>cc</sub> | V        |       |
|                                  | Normal  | 0               |             | 0.8             | V        |       |

| Receiver                       |                  |      |  |                 |     |   |
|--------------------------------|------------------|------|--|-----------------|-----|---|
| Centre Wavelength              | $\lambda_c$      | 1260 |  | 1620            | nm  |   |
| Receiver Sensitivity           |                  |      |  | -34             | dBm | 3 |
| Receiver Overload              |                  | -3   |  |                 | dBm | 3 |
| LOS De-Assert                  | LOS <sub>D</sub> |      |  | -38             | dBm |   |
| LOS Assert                     | LOS <sub>A</sub> | -45  |  |                 | dBm |   |
| LOS Hysteresis                 |                  | 1    |  | 4               | dB  |   |
| Data Output Swing Differential | V <sub>out</sub> | 370  |  | 1800            | mV  | 4 |
| LOS                            | High             | 2.0  |  | V <sub>cc</sub> | V   |   |
|                                | Low              | 0    |  | 0.8             | V   |   |

**Notes:**

1. The optical power is launched into SMF.
2. PECL input, internally AC-coupled and terminated.
3. Measured with a PRBS 2<sup>23</sup>-1 test pattern @155Mbps, BER  $\leq 1 \times 10^{-12}$ .
4. Internally AC-coupled.

## Timing and Electrical

**Table 5 - Timing and Electrical**

| Parameter                                       | Symbol                    | Min | Typical | Max             | Unit    |
|---|---------------------------|-----|---------|-----------------|---------|
| Tx Disable Negate Time                          | t <sub>on</sub>           |     |         | 1               | ms      |
| Tx Disable Assert Time                          | t <sub>off</sub>          |     |         | 10              | $\mu$ s |
| Time To Initialize, including Reset of Tx Fault | t <sub>init</sub>         |     |         | 300             | ms      |
| Tx Fault Assert Time                            | t <sub>fault</sub>        |     |         | 100             | $\mu$ s |
| Tx Disable To Reset                             | t <sub>reset</sub>        | 10  |         |                 | $\mu$ s |
| LOS Assert Time                                 | t <sub>loss_on</sub>      |     |         | 100             | $\mu$ s |
| LOS De-assert Time                              | t <sub>loss_off</sub>     |     |         | 100             | $\mu$ s |
| Serial ID Clock Rate                            | f <sub>serial_clock</sub> |     |         | 400             | KHz     |
| MOD_DEF (0:2)-High                              | V <sub>H</sub>            | 2   |         | V <sub>cc</sub> | V       |
| MOD_DEF (0:2)-Low                               | V <sub>L</sub>            |     |         | 0.8             | V       |

## EEPROM Information

The SFP MSA defines a 256-byte memory map in EEPROM describing the transceiver's capabilities, standard interfaces, manufacturer, and other information, which is accessible over a 2 wire serial interface at the 8-bit address 1010000X (A0h). The memory contents refer to Table 6.

**Table 6 - EEPROM Serial ID Memory Contents (A0h)**

| Addr. | Field Size (Bytes) | Name of Field   | Hex  | Description                  |
|-------|--------------------|-----------------|--|------------------------------|
| 0     | 1                  | Identifier      | 03   | SFP                          |
| 1     | 1                  | Ext. Identifier | 04   | MOD4                         |
| 2     | 1                  | Connector       | 07   | LC                           |
| 3—10  | 8                  | Transceiver     | 00 08 04 00 00 00 00 00                            | OC-3, Single mode long reach |
| 11    | 1                  | Encoding        | 03   | NRZ                          |
| 12    | 1                  | BR, nominal     | 02   | 155Mbps                      |
| 13    | 1                  | Reserved        | 00   |                              |
| 14    | 1                  | Length (9um)-km | 78   | 120km                        |
| 15    | 1                  | Length (9um)    | FF   |                              |
| 16    | 1                  | Length (50um)   | 00   |                              |
| 17    | 1                  | Length (62.5um) | 00   |                              |
| 18    | 1                  | Length (copper) | 00   |                              |
| 19    | 1                  | Reserved        | 00   |                              |
| 20—35 | 16                 | Vendor name     | 47 69 67 61 6C 69 67 68 74<br>20 20 20 20 20 20 20 | "Empowerfiber"(ASCII)        |
| 36    | 1                  | Reserved        | 00   |                              |
| 37—39 | 3                  | Vendor OUI      | 00 00 00   |                              |
| 40—55 | 16                 | Vendor PN       | 47 50 43 2D 34 35 30 33 2D<br>31 32 43 44 20 20 20 | "GPC-4503-12CD"(ASCII)       |
| 56—59 | 4                  | Vendor rev      | xx xx xx xx  | xx.xx revision (ASCII)       |
| 60-61 | 2                  | Wavelength      | 05 AA  | 1450nm                       |
| 62    | 1                  | Reserved        | 00   |                              |
| 63    | 1                  | CC BASE         | xx   | Check sum of bytes 0 - 62    |
| 64—65 | 2                  | Options         | 00 1A  | LOS, TX_FAULT and TX_DISABLE |
| 66    | 1                  | BR, max         | 00   |                              |
| 67    | 1                  | BR, min         | 00   |                              |

|        |     |                  |  |   |
|--------|-----|------------------|--|---|
| 68—83  | 16  | Vendor SN        | xx xx xx xx xx xx xx xx xx xx<br>xx xx xx xx xx xx | ASC II                                    |
| 84—91  | 8   | Vendor date code | xx xx xx xx xx xx 20 20                            | Year(2 bytes),Month(2 bytes),Day(2 bytes) |
| 92     | 1   | Diagnostic type  | xx   | Diagnostics                               |
| 93     | 1   | Enhanced option  | 80   | Diagnostics(Optional Alarm/warning flags) |
| 94     | 1   | SFF-8472         | 01   | Diagnostics(SFF-8472 Rev 9.3)             |
| 95     | 1   | CC EXT           | xx   | Check sum of bytes 64 - 94                |
| 96—255 | 160 |                  |  |   |

## Diagnostics

**Table 7 – Diagnostics Specification**

| Parameter    | Range      | Unit | Accuracy | Calibration         |
|--------------|------------|------|----------|---------------------|
| Temperature  | 0 to +70   | °C   | ±3°C     | Internal / External |
| Voltage      | 3.0 to 3.6 | V    | ±3%      | Internal / External |
| Bias Current | 0 to 100   | mA   | ±10%     | Internal / External |
| TX Power     | 0 to +5    | dBm  | ±3dB     | Internal / External |
| RX Power     | -33 to -9  | dBm  | ±3dB     | Internal / External |

### Digital Diagnostic Memory Map

The transceivers provide serial ID memory contents and diagnostic information about the present operating conditions by the 2-wire serial interface (SCL, SDA).

The diagnostic information with internal calibration or external calibration all are implemented, including received power monitoring, transmitted power monitoring, bias current monitoring, supply voltage monitoring and temperature monitoring.

The digital diagnostic memory map specific data field defines as following.

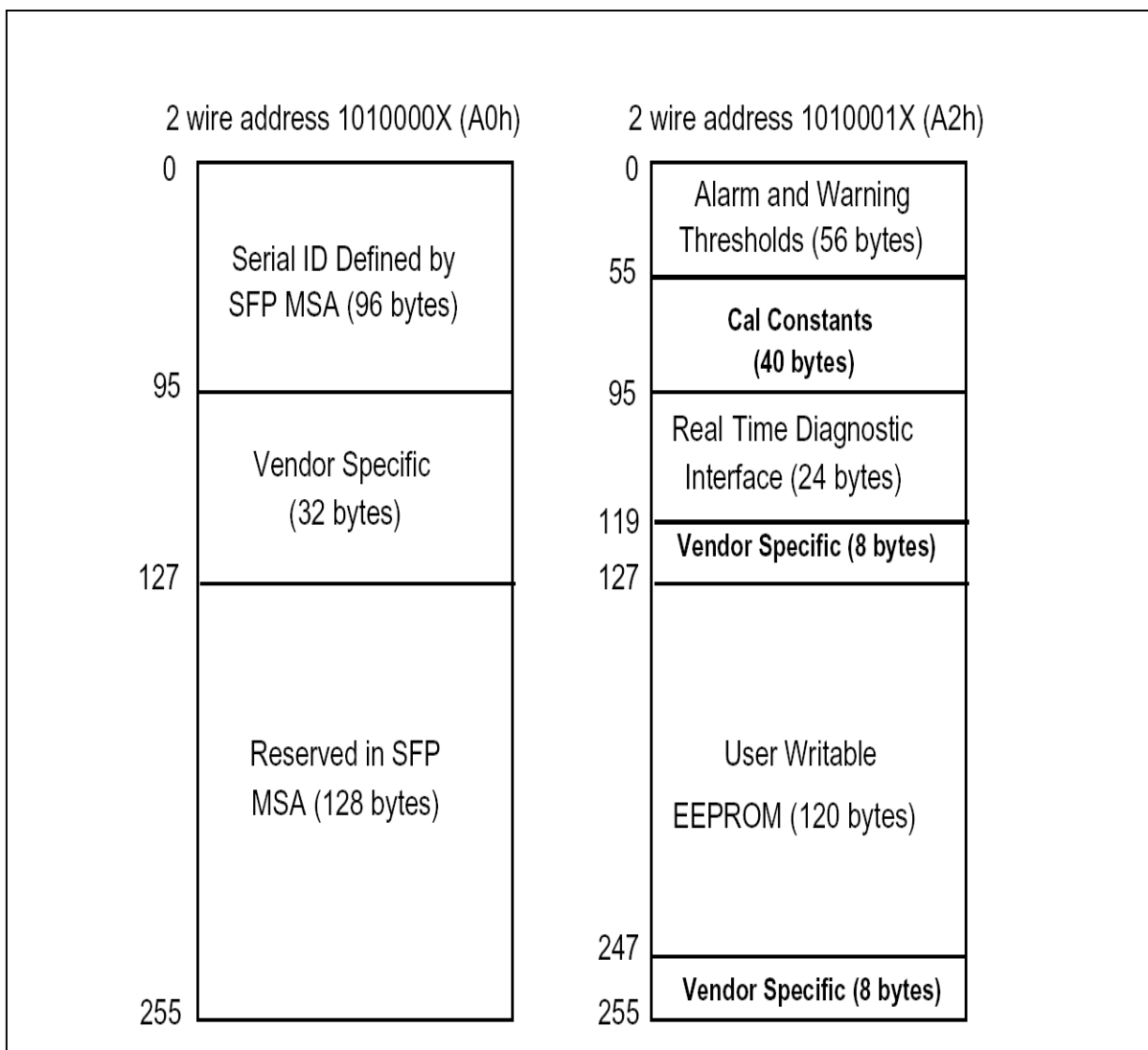

**Pin Definitions**

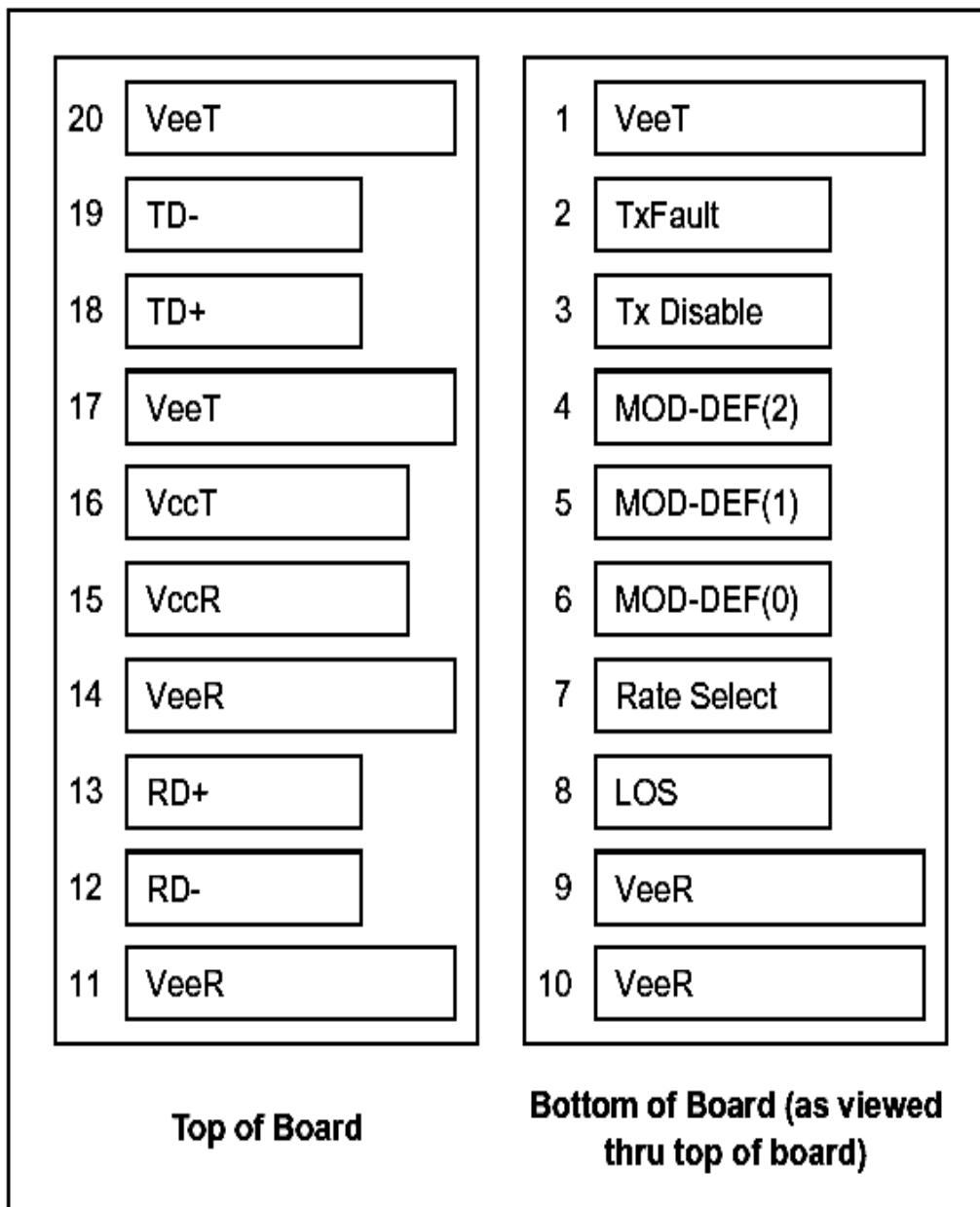



## Pin Descriptions

| Pin | Signal Name      | Description                  | Plug Seq. | Notes  |
|-----|------------------|------------------------------|-----------|--------|
| 1   | V <sub>EET</sub> | Transmitter Ground           | 1         |        |
| 2   | TX FAULT         | Transmitter Fault Indication | 3         | Note 1 |
| 3   | TXDISABLE        | Transmitter Disable          | 3         | Note 2 |
| 4   | MOD_DEF(2)       | SDA Serial Data Signal       | 3         | Note 3 |
| 5   | MOD_DEF(1)       | SCL Serial Clock Signal      | 3         | Note 3 |
| 6   | MOD_DEF(0)       | TTL Low                      | 3         | Note 3 |
| 7   | Rate Select      | Not Connected                | 3         |        |
| 8   | LOS              | Loss of Signal               | 3         | Note 4 |
| 9   | V <sub>EER</sub> | Receiver ground              | 1         |        |
| 10  | V <sub>EER</sub> | Receiver ground              | 1         |        |
| 11  | V <sub>EER</sub> | Receiver ground              | 1         |        |
| 12  | RD-              | Inv. Received Data Out       | 3         | Note 5 |
| 13  | RD+              | Received Data Out            | 3         | Note 5 |
| 14  | V <sub>EER</sub> | Receiver ground              | 1         |        |
| 15  | V <sub>CCR</sub> | Receiver Power Supply        | 2         |        |
| 16  | V <sub>CCT</sub> | Transmitter Power Supply     | 2         |        |
| 17  | V <sub>EET</sub> | Transmitter Ground           | 1         |        |
| 18  | TD+              | Transmit Data In             | 3         | Note 6 |
| 19  | TD-              | Inv. Transmit Data In        | 3         | Note 6 |
| 20  | V <sub>EET</sub> | Transmitter Ground           | 1         |        |

### Notes:

Plug Seq.: Pin engagement sequence during hot plugging.

- TX Fault is an open collector output, which should be pulled up with a 4.7k~10kΩ resistor on the host board to a voltage between 2.0V and V<sub>cc</sub>+0.3V. Logic 0 indicates normal operation; Logic 1 indicates a laser fault of some kind. In the low state, the output will be pulled to less than 0.8V.
- TX Disable is an input that is used to shut down the transmitter optical output. It is pulled up within the module with a 4.7k~10kΩ resistor. Its states are:
 

|                       |                      |
|-----------------------|----------------------|
| Low (0 to 0.8V):      | Transmitter on       |
| (>0.8V, < 2.0V):      | Undefined            |
| High (2.0 to 3.465V): | Transmitter Disabled |
| Open:                 | Transmitter Disabled |
- Mod-Def 0,1,2. These are the module definition pins. They should be pulled up with a 4.7k~10kΩ resistor on the host board. The pull-up voltage shall be V<sub>ccT</sub> or V<sub>ccR</sub>.  
 Mod-Def 0 is grounded by the module to indicate that the module is present  
 Mod-Def 1 is the clock line of two wire serial interface for serial ID  
 Mod-Def 2 is the data line of two wire serial interface for serial ID
- LOS is an open collector output, which should be pulled up with a 4.7k~10kΩ resistor. Pull up voltage between 2.0V and V<sub>cc</sub>+0.3V. Logic 1 indicates loss of signal; Logic 0 indicates normal operation. In the low state, the output will be pulled to less than 0.8V.
- RD-/+ : These are the differential receiver outputs. They are internally AC-coupled 100 differential lines which should be terminated with 100Ω (differential) at the user SERDES.
- TD-/+ : These are the differential transmitter inputs. They are internally AC-coupled, differential lines with 100Ω differential termination inside the module.

### Recommended Interface Circuit

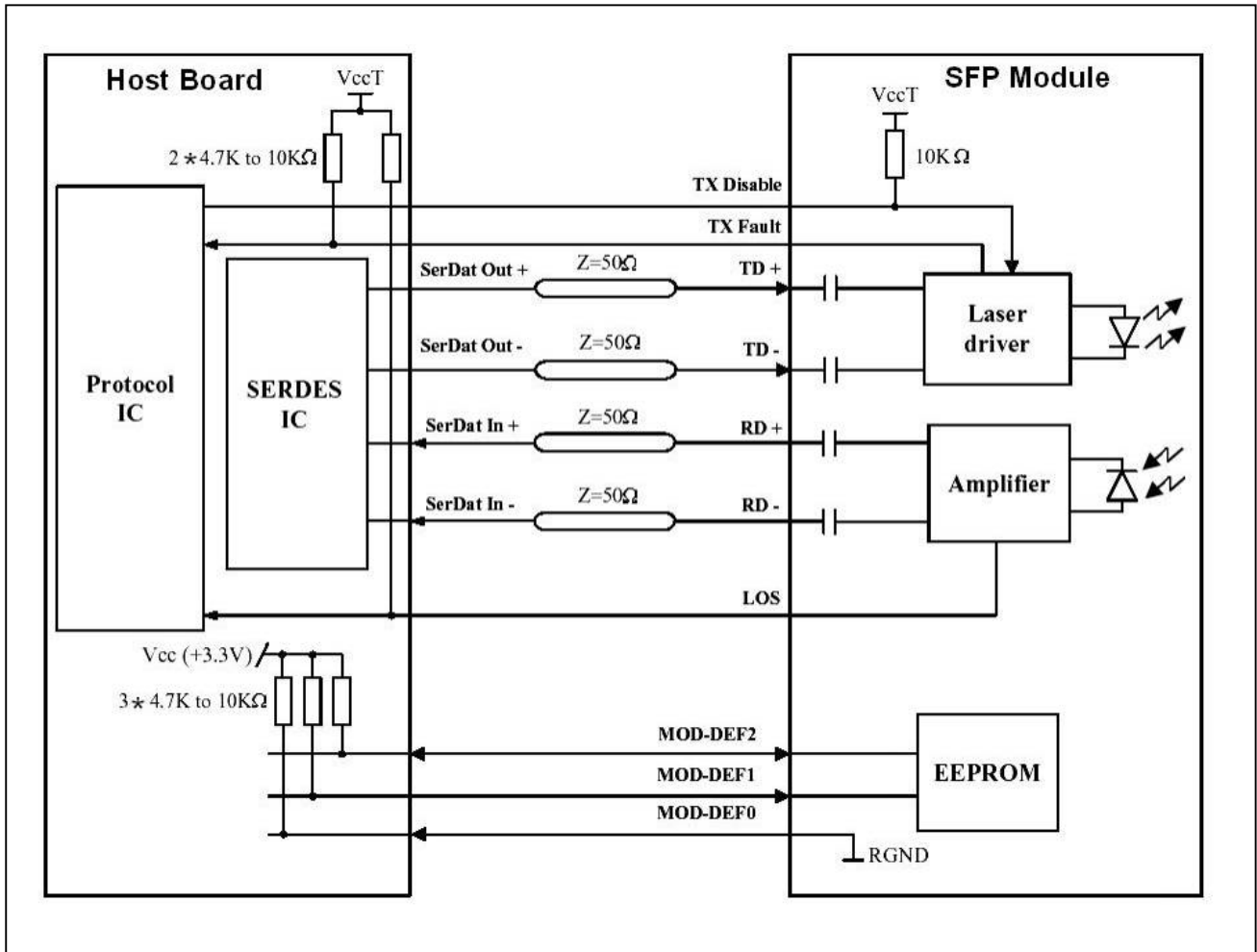

### Mechanical Dimensions

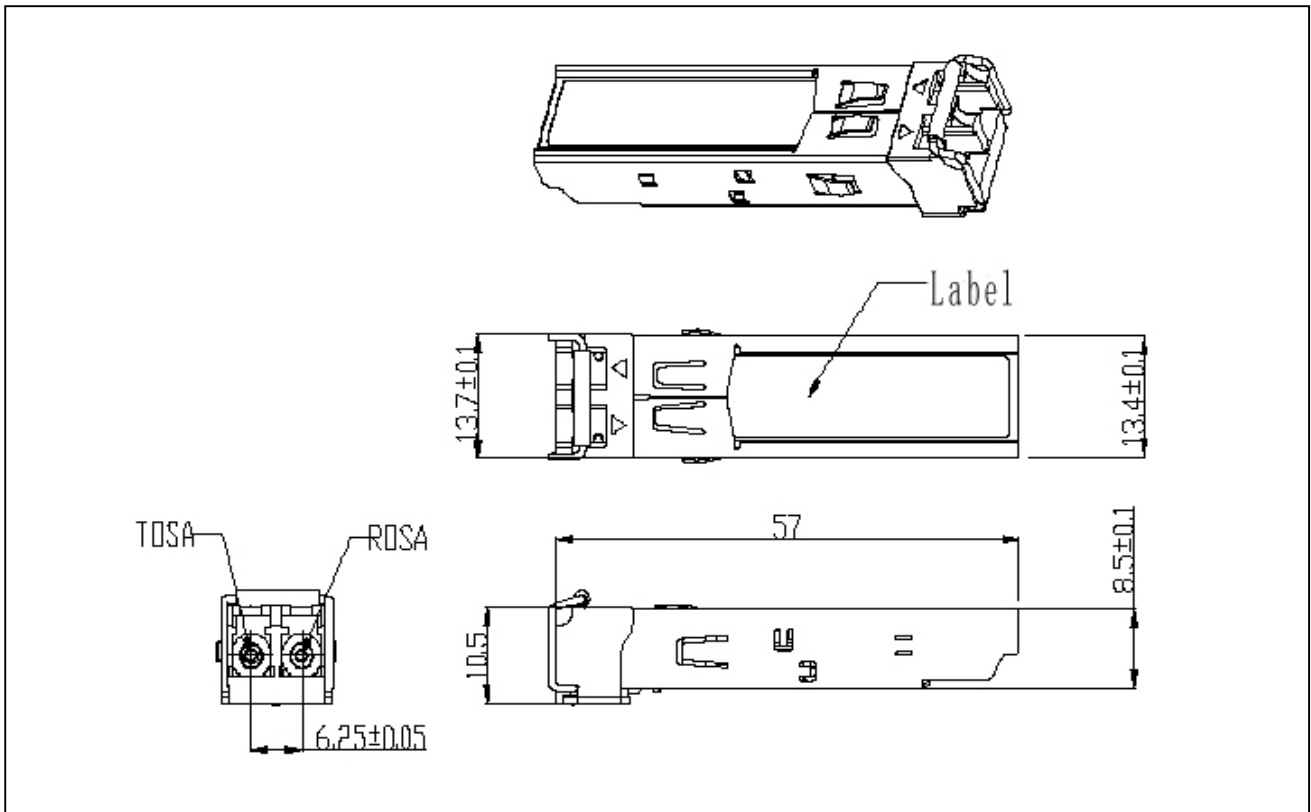

### Regulatory Compliance

Empowerfiber SFP transceiver is designed to be Class I Laser safety compliant and is certified per the following standards

| Feature                  | Agency | Standard  | Certificate / Comments |
|--------------------------|--------|---|------------------------|
| Laser Safety             | FDA    | CDRH 21 CFR 1040 and Laser Notice No. 50                    | 1120294-000            |
| Product Safety           | BST    | EN 60825-1: 2007<br>EN 60825-2: 2004<br>EN 60950-1: 2006    | BT0905142002           |
| Environmental protection | SGS    | RoHS Directive 2002/95/EC                                   | GZ0902008346/CHEM      |
| EMC                      | CCIC   | EN 55022: 2006+A1: 2007<br>EN 55024: 1998+A1: 2001+A2: 2003 | CTE09050018            |

### **Important Notice**

Performance figures, data and any illustrative material provided in this data sheet are typical and must be specifically confirmed in writing by empowerfiber before they become applicable to any particular order or contract. In accordance with the empowerfiber policy of continuous improvement specifications may change without notice.

The publication of information in this data sheet does not imply freedom from patent or other protective rights of empowerfiber or others. Further details are available from any empowerfiber sales representative.

E-mail: [sales@empowerfiber.com](mailto:sales@empowerfiber.com)

Web : <http://www.empowerfiber.com>