

## EPP-31192-LRMC 10Gbps 220m Multi Mode Datacom SFP+ Transceiver

### Features

- ◆ Supports 9.95 to 10.3Gbps bit rates
- ◆ Transmission distance up to 220m (OM1 fiber)
- ◆ Hot Pluggable SFP+ footprint
- ◆ 1310nm FP transmitter, PIN photo-detector
- ◆ Digital Status monitoring Interface
- ◆ Duplex LC connector
- ◆ RoHS compliant and Lead Free
- ◆ Metal enclosure for lower EMI
- ◆ Single 3.3V power supply
- ◆ Power dissipation < 1W
- ◆ Operating case temperature: 0 to 70°C
- ◆ Compliant with FC-PI-4 800-Mx-SN-I, SFF-8431 , SFF-8432 and SFF-8472



### Applications

- ◆ 10GBASE-LRM 10G Ethernet
- ◆ Legacy FDDI multimode links

### Product description

Empowerfiber' SFP+ LRM is an optical transceiver module for transmission at 1310nm over legacy multimode fiber. Supporting 10GBASE-LRM Ethernet standard make it ideally suited for 10G datacom. Its very low power consumption and its excellent EMI performance allow system design with high port density. The small form factor integrates a 1310nm Fabry-Perot (FP) laser in an LC package and a linear multimode PIN receiver. empowerfiber module is lead free, RoHS compliant and is designed and tested in accordance with industry safety standards.

The empowerfiber EPP-31192-LRMC SFP+ transceiver is a linear-interface transceiver that enables, in conjunction with an Electronic Dispersion Compensation (EDC) on the host board, an IEEE802.3aq 10GBASE-LRM compliant link. The host board EDC provides correction for the severe modal dispersion that may occur during propagation through multimode fiber links, including legacy installed FDDI multimode fiber (see IEEE802.3aq for detailed information regarding fiber coverage).

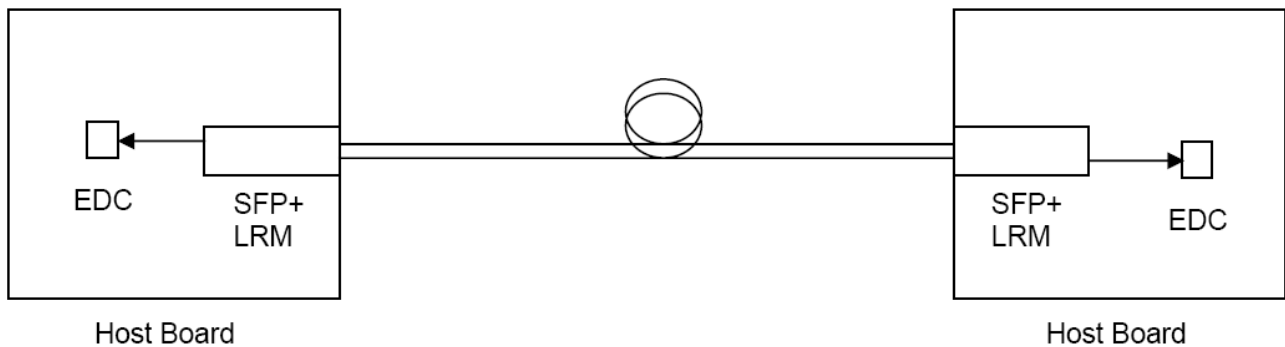

**Figure 1. Block Diagram of SFP+ LRM Module on Host Board with EDC**

Unlike the XFP MSA transceiver requirements, the SFP+ transceiver does not contain internal retiming circuitry, and thus some of the Transmitter Optical Characteristics stated in this data sheet require that the Host Board is compliant to the SFP+ MSA specifications. See Chapter 3 in Reference [1] for further details.

### Absolute maximum rating

These values represent the damage threshold of the module. Stress in excess of any of the individual Absolute Maximum Ratings can cause immediate catastrophic damage to the module even if all other parameters are within Recommended Operating Conditions.

Parameters	Symbol	Min.	Max.	Unit
Power Supply Voltage	$V_{CC}$	0	+3.6	V
Storage Temperature	$T_c$	-40	+85	°C
Operating Case Temperature	$T_c$	0	+70	°C
Relative Humidity	RH	5	95	%

### Recommended operating environment

Recommended Operating Environment specifies parameters for which the electrical and optical characteristics hold unless otherwise noted.

Parameter	Symbol	Min.	Typical	Max	Unit
Power Supply Voltage	$V_{CC}$	3.135	3.300	3.465	V
Operating Case Temperature	$T_c$	0	25	70	°C

**LOW Speed Characteristics**

Parameter	Symbol	Min.	Typical	Max	Unit
Power Consumption			0.8	1	W
TX_Fault,RX_LOS	VOL	0		0.4	V
	VOH	Host_Vcc-0.5		Host_Vcc+0.3	V
TX_DIS	VIL	-0.3		0.8	V
	VIH	2.0		VCCT+0.3	V
RS0,RS1	VIL	-0.3		0.8	V
	VIH	2.0		VCCT+0.3	V

**Electrical characteristics**

Parameter	Conditions	Symbol	Min.	Typical	Max	Unit
Nominal Data Rate		VID		10.3125		Gbps
Supply Voltage		Vcc	3.14		3.46	V
Supply Current		Icc		200	300	mA
Power Dissipation		P			1	W
<b>Transmitter</b>						
Input differential impedance	2	R <sub>in</sub>		100		Ω
Single ended data input swing	3	V <sub>in,pp</sub>	90		350	mV
Transmit Disable Voltage	4	V <sub>D</sub>	2		Vcc	V
Transmit Enable Voltage		V <sub>EN</sub>	Vee		Vee+0.8	V
<b>Receiver</b>						
Termination Mismatch at 1 MHz		ΔZ <sub>M</sub>			5	%
Single Ended Output Voltage Tolerance			-0.3		4.0	V
Output AC Common Mode Voltage					7.5	mV RMS
Output Rise and Fall time (20% to 80%)	5	Tr, Tf	30			Ps
Relative Noise LRM Links with crosstalk	6	dRNx			TBD equation	dB/Hz
Difference Waveform Distortion Penalty	7	dWDP		per SFF-8431		dB
Differential Voltage Modulation Amplitude		VMA	180		600	mV
LOS Fault	8	V <sub>LOS fault</sub>	2		VcCHOST	V
LOS Normal	8	V <sub>LOS norm</sub>	Vee		Vee+0.8	V
Power Supply Noise Tolerance	9	VccT/VccR		per SFF-8431		mVpp

**Notes:**

1. Non-condensing.
2. Connected directly to TX data input pins. AC coupling from pins into laser driver IC.
3. Per SFF-8431 Rev 3.0
4. Into 100 ohms differential termination.
5. Measured with Module Compliance Test Board and OMA test pattern.
6. Crosstalk source rise/fall time (20%-80%) is 35 ps.
7. Defined with reference receiver with 14 T/2 spaced FFE taps and 5 T spaced DFE taps.
8. LOS is an open collector output. Should be pulled up with 4.7k – 10kΩ on the host board. Normal operation is logic 0; loss of signal is logic 1. Maximum pull-up voltage is 5.5V.
9. As described in Section 2.8.1, SFF-8431 Rev 3.0.

**General Specifications**

Parameter		Symbol	Min.	Typical	Max	Unit	Notes
Bit Rate		BR		10.3125		Gb/sec	1
Bit Error Ratio		BER			10 <sup>-12</sup>		2
Maximum Supported Distances							
Fiber Type	1310nm OFL Bandwidth						
62.5µm	“FDDI” 160MHz/km OM1	Lmax			220	m	3
	200MHz/km				220		
50µm	400MHz/km	Lmax			100	m	3
	OM2 500MHz/km				220		
	OM3 2000MHz/km				220		

**Notes:**

1. 10GBASE-LRM
2. Tested with a 231 – 1 PRBS
3. Operating range as defined by IEEE standards. Longer reach possible depending upon link implementation.

**Optical characteristics**

Parameter	Symbol	Min.	Typical	Max	Unit	Notes
<b>Transmitter</b>						
Center Wavelength	$\lambda_t$	1260		1355	nm	
RMS spectral width	$\lambda_{rms}$ @1260nm			2.4		2
	$\lambda_{rms}$ @ 1260nm-1300	-	-	2.4	nm	
	$\lambda_{rms}$ @ 1300nm-1355			4		
Average Optical Power	$P_{avg}$	-6.5	-	0.5	dBm	1
Extinction Ratio	ER	3.5	-	-	dB	
Optical Modulation Amplitude (OMA)	POMA	-4.5		+1.5	dBm	
Peak Launch Power	P <sub>MAX</sub>			3	dBm	
Transmitter Waveform Dispersion Penalty	TWDP			4.7	dB	3
Average Launch power of OFF transmitter	POFF			-30	dBm	
Uncorrelated Jitter [rms]	T <sub>xj</sub>			0.033	UI	
Encircled Flux	<5 $\mu$ m	30			%	
	<11 $\mu$ m	81				
Transmitter Reflectance				-12	dB	
Optical Return Loss Tolerance		20			dB	
Relative Intensity Noise	R <sub>in</sub>			-128	dB/Hz	
<b>Receiver</b>						
Comprehensive Stressed Receiver Sensitivity (OMA) @ 10.3125Gb/s	Precursor	-	-	-6.5	dBm	5
	Symmetrical			-6	dBm	
	Postcursor			-6.5	dBm	
LOS Assert	LosA	-30	-		dBm	
LOS De-assert	LosD			-11	dBm	
Overload	P <sub>MAX</sub>	+1.5	-		dBm	4
Receiver Reflectance		-	-	-12	dB	
LOS Hysteresis		0.5			dB	

**Notes:**

1. Average power figures are informative only, per IEEE802.3aq
2. Maximum RMS spectral width as specified by Figure 3
3. Optical Eye Mask requires the host board to be SFF-8431 compliant. Optical eye mask per IEEE802.3aq.
4. TWDP figure requires the host board to be SFF-8431 compliant. TWDP is calculated using the Matlab code provided in clause 68.6.6.2 of IEEE802.3aq
5. Receiver overload specified in OMA and under the worst comprehensive stressed condition.
6. Conditions of stressed receiver tests per IEEE802.3aq. CSRS testing requires the host board to be SFF-8431 compliant.

### Digital Diagnostic Functions

The following digital diagnostic characteristics are defined over the Recommended Operating Environment unless otherwise specified. It is compliant to SFF8472 Rev9.2 with internal calibration mode. For external calibration mode please contact our sales staff.

Parameter	Symbol	Min.	Max	Unit	Notes
<b>Accuracy</b>					
Transceiver Temperature	DMI_Temp	-3	+3	degC	Over operating temp
TX Output optical power	DMI_TX	-3	+3	dBm	
RX Input optical power	DMI_RX	-3	+3	dBm	-3dBm to -12dBm range
Transceiver Supply voltage	DMI_VCC	-0.08	+0.08	V	Full operating range
Bias current monitor	DMI_Ibias	-10%	10%	mA	
<b>Dynamic Range Accuracy</b>					
Transceiver Temperature	DMI_Temp	-5	70	degC	
TX Output optical power	DMI_TX	-9	-1	dBm	
RX Input optical power	DMI_RX	-18	0	dBm	
Transceiver Supply voltage	DMI_VCC	3.0	3.6	V	
Bias current monitor	DMI_Ibias	0	70	mA	

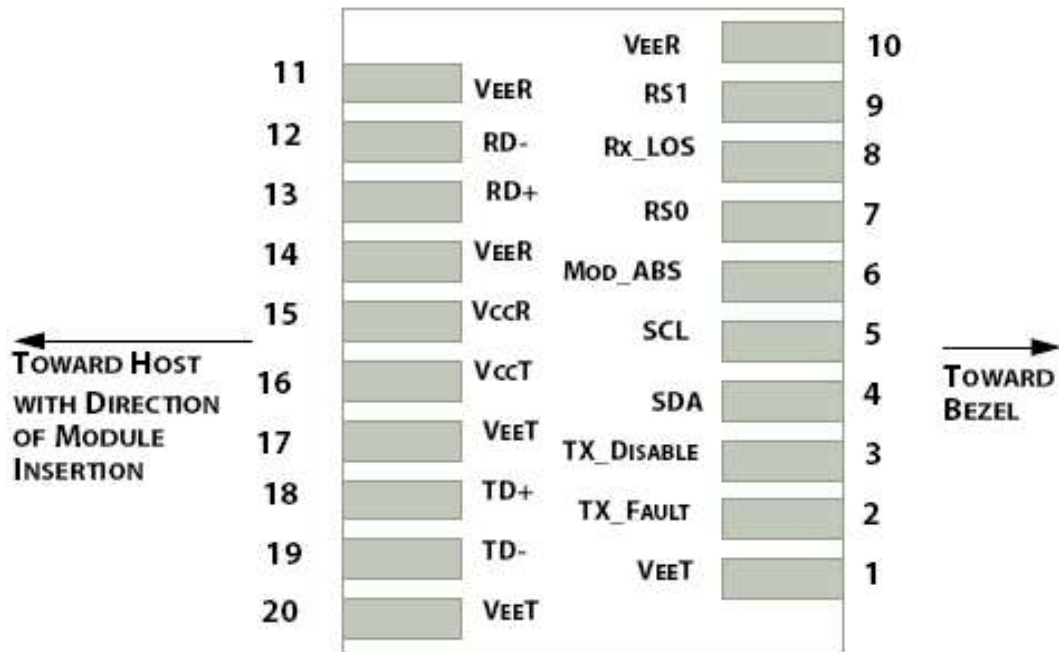

**Figure 2: Interface to Host PCB**

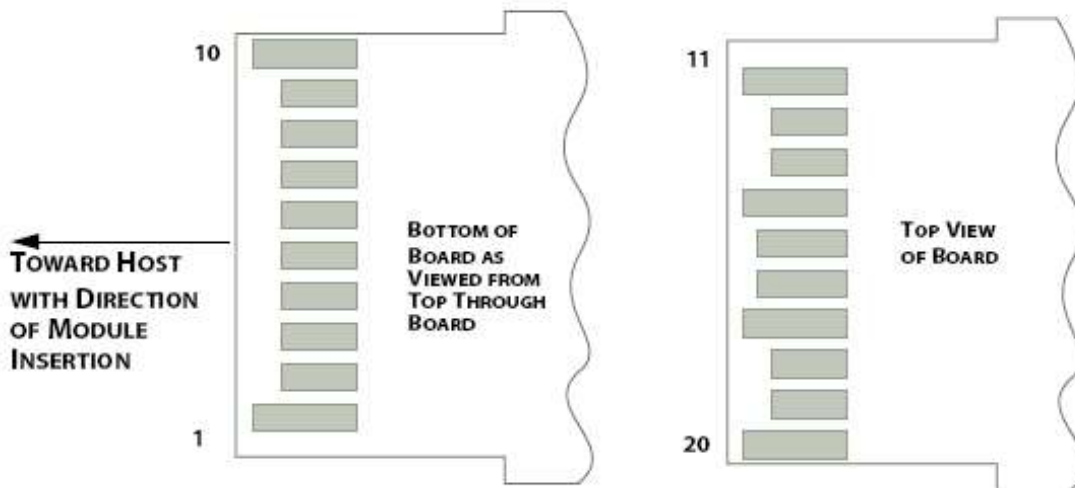

**Figure 3: Module Contact Assignment**

## Pin definition

Pin	Symbol	Name/Description
1	VEET [1]	Transmitter Ground
2	Tx_FAULT [2]	Transmitter Fault
3	Tx_DIS [3]	Transmitter Disable. Laser output disabled on high or open
4	SDA [2]	2-wire Serial Interface Data Line
5	SCL [2]	2-wire Serial Interface Clock Line
6	MOD_ABS [4]	Module Absent. Grounded within the module
7	RS0 [5]	Rate Select 0
8	RX_LOS [2]	Loss of Signal indication. Logic 0 indicates normal operation
9	RS1 [5]	Rate Select 1
10	VEER [1]	Receiver Ground
11	VEER [1]	Receiver Ground
12	RD-	Receiver Inverted DATA out. AC Coupled
13	RD+	Receiver DATA out. AC Coupled
14	VEER [1]	Receiver Ground
15	VCCR	Receiver Power Supply
16	VCCT	Transmitter Power Supply
17	VEET [1]	Transmitter Ground
18	TD+	Transmitter DATA in. AC Coupled
19	TD-	Transmitter Inverted DATA in. AC Coupled
20	VEET [1]	Transmitter Ground

### Notes:

[1] Module circuit ground is isolated from module chassis ground within the module.

[2].should be pulled up with 4.7k – 10k ohms on host board to a voltage between 3.15V and 3.6V.

[3]Tx\_Disable is an input contact with a 4.7 kΩ to 10 kΩ pullup to VccT inside the module.

[4]Mod\_ABS is connected to VeeT or VeeR in the SFP+ module. The host may pull this contact up to Vcc\_Host with a resistor in the range 4.7 kΩ to 10 kΩ. Mod\_ABS is asserted “High” when the SFP+ module is physically absent from a host slot.

[5] RS0 and RS1 are module inputs and are pulled low to VeeT with > 30 kΩ resistors in the module.



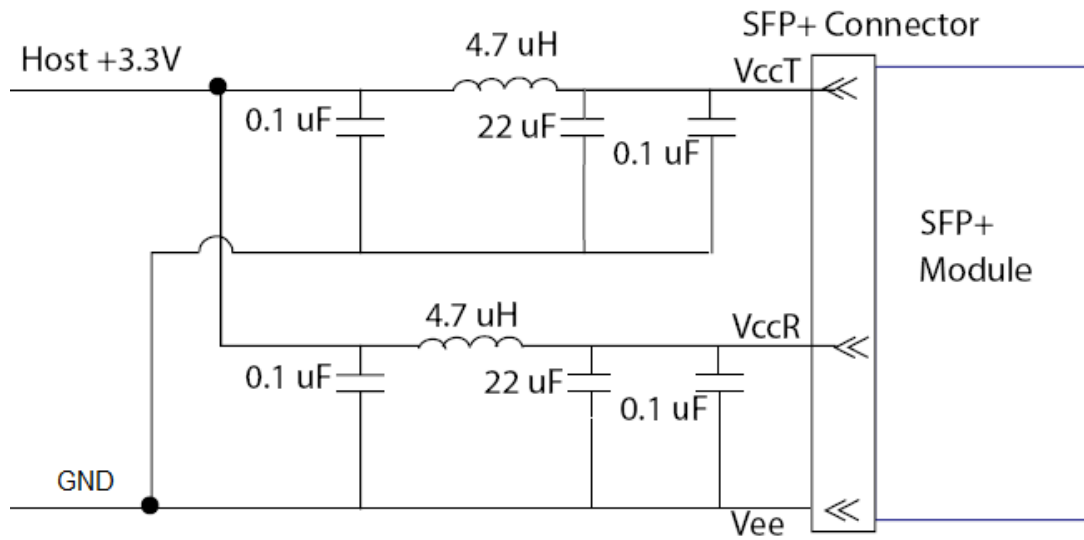

Figure4. Host Board Power Supply Filters Circuit

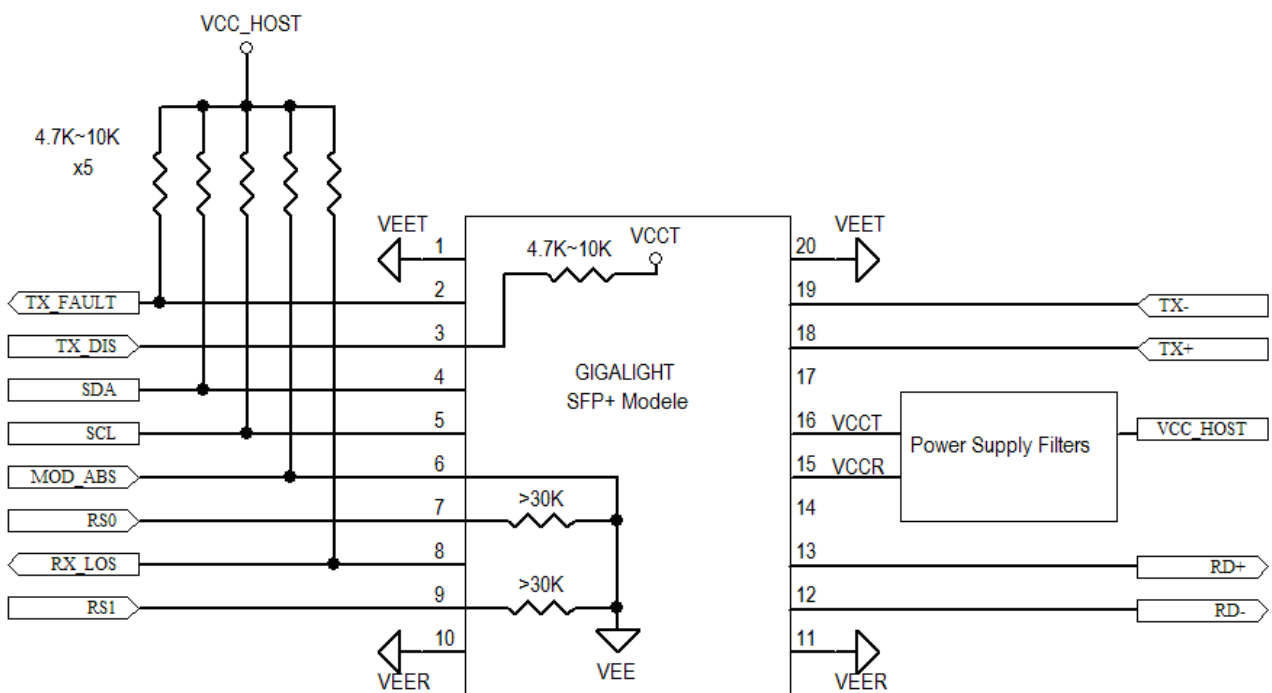
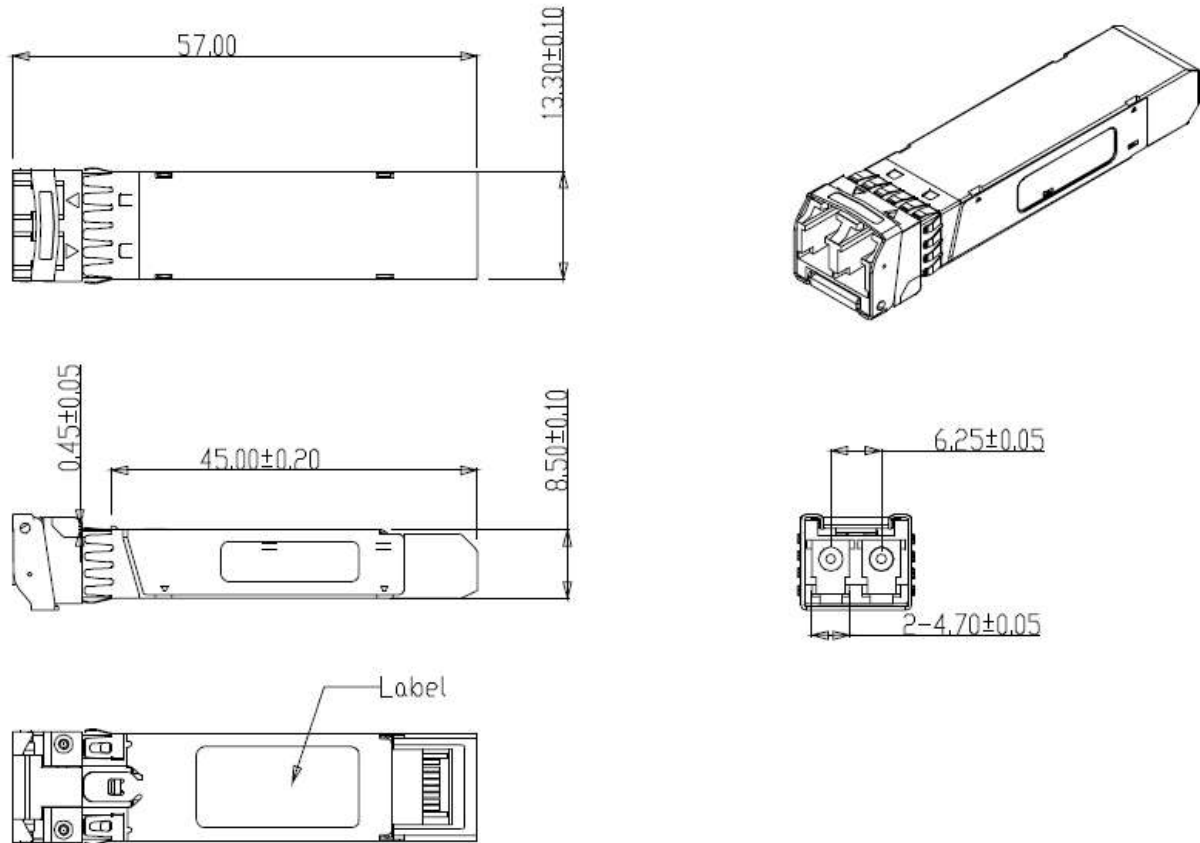

Figure5. Host-Module Interface



**Figure6. Mechanical Specifications**

**Regulatory Compliance**

EMPOWERFIBER SFP+ transceiver is designed to be Class I Laser safety compliant and is certified per the following standards:

Feature	Agency	Standard	Certificate / Comments
Laser Safety	FDA	CDRH 21 CFR 1040 annd Laser Notice No. 50	1120292-000
Product Safety	UL	UL and CUL EN60950-2:2007	E347511
Environmental protection	SGS	RoHS Directive 2002/95/EC	GZ1001008918/CHEM
EMC	WALTEK	EN 55022:2006+A1:2007 EN 55024:1998+A1+A2:2003	WT10093759-D-E-E

**Ordering information**

Part Number	Product Description
EPP-31192-LRMC	1310nm, 10.3125Gpbs, Multi Mode 220m, 0°C ~ +70°C

**References**

1. "Specifications for Enhanced Small Form Factor Pluggable Module SFP+", SFF-8431, Rev 4.1, July 6, 2009.
2. "Improved Pluggable Formfactor", SFF-8432, Rev 4.2, Apr 18, 2007
3. IEEE802.3aq
4. "Diagnostic Monitoring Interface for Optical Transceivers" SFF-8472, Rev 10.3, Dec 1, 2007

**Important Notice**

Performance figures, data and any illustrative material provided in this data sheet are typical and must be specifically confirmed in writing by empowerfiber before they become applicable to any particular order or contract. In accordance with the empowerfiber policy of continuous improvement specifications may change without notice.

The publication of information in this data sheet does not imply freedom from patent or other protective rights of EMPOWERFIBER or others. Further details are available from any EMPOWERFIBER sales representative.

E-mail: [sales@empowerfiber.com](mailto:sales@empowerfiber.com)

Web : <http://www.empowerfiber.com>