

EMPOWERFIBER 40km DWDM XFP Optical Transceiver EXD-XX192-04C

Features

- ◆ Wavelength selectable to C-band ITU-T grid wavelengths
- ◆ Suitable for use in 100GHz channel spacing DWDM systems
- ◆ XFP MSA Rev 4.5 Compliant
- ◆ Data rate from 9.95Gbps to 11.3Gbps
- ◆ No Reference Clock required
- ◆ Cooled EML and PIN receiver
- ◆ link length up to 40km
- ◆ Low Power Dissipation 3.5W Maximum
- ◆ XFI and lineside loopback Mode Supported
- ◆ -5°C to 70°C Operating Case Temperature
- ◆ Diagnostic Performance Monitoring of module temperature, Supply Voltages, laser bias current, transmit optical power, and receive optical power
- ◆ RoHS6 compliant (lead free) 



Applications

- ◆ SONET OC-192 & SDH STM 64
- ◆ 10GBASE ER/EW
- ◆ 40km 10G Fiber Channel
- ◆ DWDM Networks

Description

Empowerfiber DWDM XFP Transceiver exhibits excellent wavelength stability, supporting operation at 100 GHz channel, cost effective module. It is designed for 10G DWDM SDH, 10GBASE-ER/EW and 10G Fiber- Channel applications.

The transceiver consists of two sections: The transmitter section incorporates a cooled EML laser. And the receiver section consists of a PIN photodiode integrated with a TIA. All modules satisfy class I laser safety requirements. Empowerfiber DWDM XFP transceiver provides an enhanced monitoring interface, which allows real-time access to device operating parameters such as transceiver temperature, laser bias current, transmitted optical power, received optical power and transceiver supply voltage.

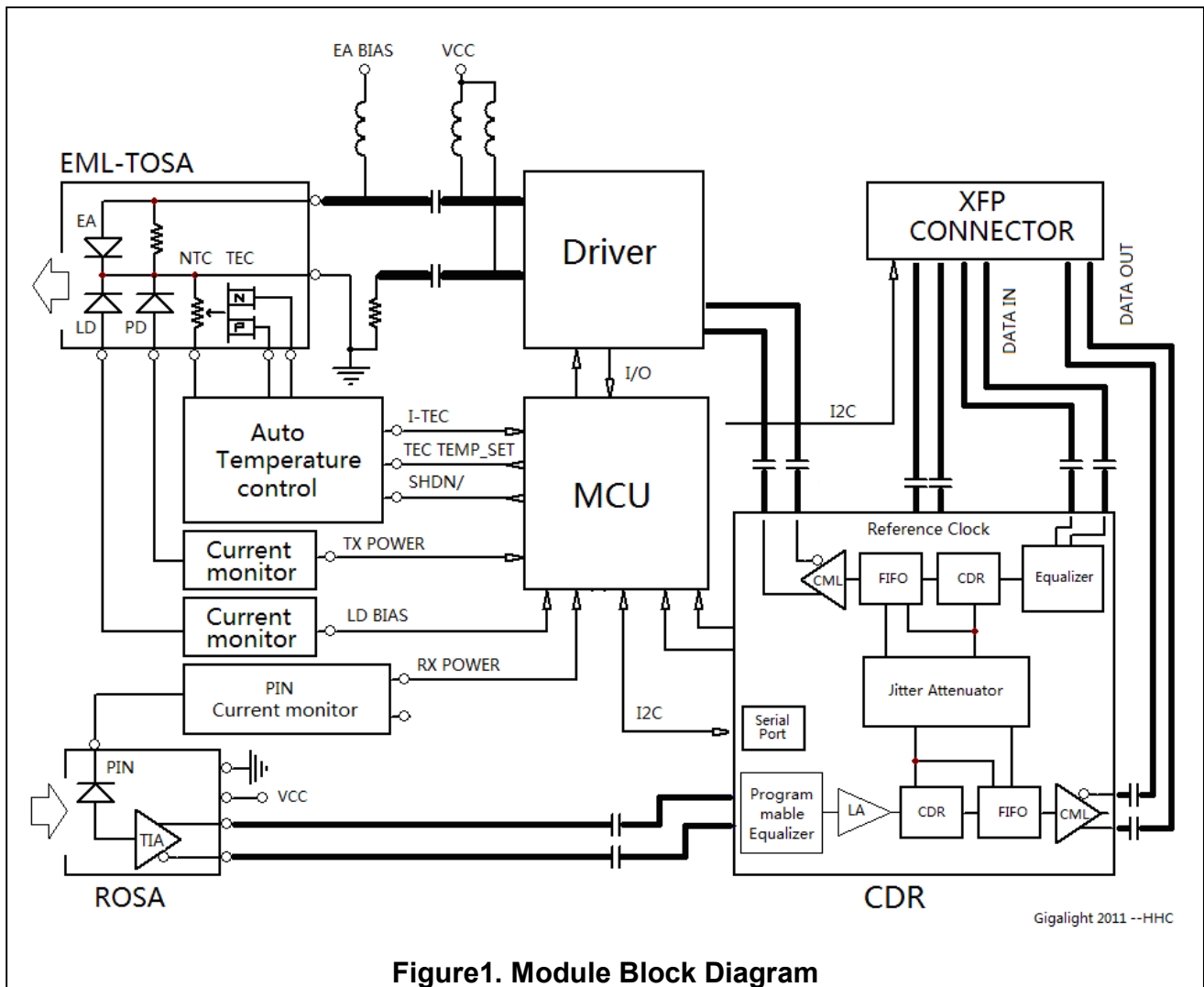

Figure1. Module Block Diagram

Absolute Maximum Ratings

Parameter	Symbol	Min	Max	Unit
Supply Voltage 1	Vcc3	-0.5	4.0	V
Supply Voltage 2	Vcc5	-0.5	6.0	V
Supply Voltage 3	Vcc2	-0.5	2	V
Storage Temperature	Tst	-40	85	°C
Case Operating Temperature	Top	-5	70	°C

Operating Conditions

Parameter	Symbol	Min	Typical	Max	Unit
Supply Voltage 1	Vcc3	3.13	3.3	3.47	V
Supply current 1	Icc3	-	-	380	mA
Supply Voltage 2	Vcc5	4.75	5	5.25	V
Supply current 2	Icc5[1]	-	-	350	mA
Supply Voltage 3	Vcc2	1.71	1.8	1.89	V
Supply current 3	Icc2	-	-	680	mA
Operating Case temperature	Tca	-5	-	70	°C
Module Power Dissipation	Pm	-	-	3.5[1]	W

Note:

1. Maximum total power value is specified across the full temperature and voltage range.

Transmitter Specifications – Optical

Parameter	Symbol	Min	Typical	Max	Unit
Center Wavelength-Start of Life [1]	c	c-25	c	c+25	pm
Center Wavelength-End of life [1]	c	c-100	c	c+100	pm
Optical Transmit Power	Po	-1	-	+2	dBm
Optical Transmit Power (disabled)	PTX_DIS	-	-	-30	dBm
Extinction Ratio	ER	8.2	-	-	dB
Jitter Generation(P-P)	JG P-P	-	-	0.1	UI
Jitter Generation(RMS)	JG RMS	-	-	0.01	UI
Spectral Width (-20dB)	$\Delta\lambda_{20}$	-	-	0.3	nm
Side Mode Suppression Ratio	SMSR	30	-	-	dB
Dispersion penalty(800ps/nm) [2]	DP	-	-	2	dB
Relative Intensity Noise	RIN	-	-	-130	dB/Hz
Eye Mask	Compliant with ITU-T G.691 STM-64 eye mask				

Note:

1. Wavelength stability is achieved within 60 seconds (max) of power up.
2. BER=10⁻¹²; PRBS 2³¹-1@10.3125Gbps.

Transmitter Specifications – Electrical

Parameter	Symbol	Min	Typical	Max	Unit
Input differential impedance	Rim	-	100	-	Ω
Differential data Input	VtxDIFF	120	-	850	mV
Transmit Disable Voltage	VD	2.0	-	Vcc3+0.3	V
Transmit Enable Voltage	Ven	0	-	+0.8	V
Transmit Disable Assert Time	Vn	-	-	10	us

Receiver Specifications – Optical

Parameter	Symbol	Min	Typical	Max	Unit
Input Operating Wavelength	λ	1260	-	1610	nm
Receiver sensitivity[1] @9.95Gbps~11.3Gbps	Pavg	-	-	-16	dBm
Receiver sensitivity in 9.95Gbps~11.3Gbps (OMA) [1]	Rsen1	-	-	-14.3	dBm
Stressed receiver sensitivity in 9.95Gbps~11.3Gbps Gbps(OMA)	Rsen2	-	-	-11.3	dBm
Maximum Input Power	RX-overload	-1	-		dBm
Reflectance	Rrx	-	-	-27	dB
LOS Asserted	Lsa	-28	-	-	dBm
LOS De-Asserted	Lda	-	-	-22	dBm
LOS Hysteresis	Lh	0.5	-	-	dB

Note:

1. BER=10⁻¹²; PRBS 2³¹-1@9.95Gbps~11.3Gbps.

Receiver Specifications – Electrical

Parameter	Symbol	Min	Typical	Max	Unit
Output differential impedance	Rom	-	100	--	Ω
Differential Output Swing	Vout P-P	350	-	850	mV
Rise/Fall Time [1]	Tr / Tf	-	-	40	ps
Loss of Signal –Asserted	VOH	2	-	Vcc3+0.3-	V
Loss of Signal –Negated	VOL	GND	-	GND+0.5	V

Note:

1. 20%-80%;

Digital Diagnostic Functions

Parameter	Symbol	Min.	Max	Unit	Notes
Accuracy					
Transceiver Temperature	DMI_Temp	-3	+3	degC	Over operating temp
TX Output optical power	DMI_TX	-3	+3	dB	
RX Input optical power	DMI_RX	-3	+3	dB	0dBm to -18dBm range
Transceiver Supply voltage	DMI_VCC	-0.08	+0.08	V	Full operating range
Bias current monitor	DMI_Ibias	-10%	10%	mA	
Dynamic Range Accuracy					
Transceiver Temperature	DMI_Temp	-5	70	degC	
TX Output optical power	DMI_TX	-1	+2	dBm	
RX Input optical power	DMI_RX	-18	0	dBm	
Transceiver Supply voltage	DMI_VCC	3.0	3.6	V	
Bias current monitor	DMI_Ibias	0	100	mA	

C-band λ c Wavelength Guide

ITU Channel Product Code	Frequency (THz)	Wavelength	ITU Channel Product Code	Frequency (THz)	Wavelength
17	191.7	1563.86	40	194.0	1545.32
18	191.8	1563.05	41	194.1	1544.53
19	191.9	1562.23	42	194.2	1543.73

20	192.0	1561.42	43	194.3	1542.94
21	192.1	1560.61	44	194.4	1542.14
22	192.2	1559.79	45	194.5	1541.35
23	192.3	1558.98	46	194.6	1540.56
24	192.4	1558.17	47	194.7	1539.77
25	192.5	1557.36	48	194.8	1538.98
26	192.6	1556.55	49	194.9	1538.19
27	192.7	1555.75	50	195.0	1537.40
28	192.8	1554.94	51	195.1	1536.61
29	192.9	1554.13	52	195.2	1535.82
30	193.0	1553.33	53	195.3	1535.04
31	193.1	1552.52	54	195.4	1534.25
32	193.2	1551.72	55	195.5	1533.47
33	193.3	1550.92	56	195.6	1532.68
34	193.4	1550.12	57	195.7	1531.90
35	193.5	1549.32	58	195.8	1531.12
36	193.6	1548.51	59	195.9	1530.33
37	193.7	1547.72	60	196.0	1529.55
38	193.8	1546.92	61	196.1	1528.77
39	193.9	1546.12			

Pin Descriptions

Pin	Logic	Symbol	Name/Description	Ref.
1		GND	Module Ground	1
2		VEE5	Optional -5.2 Power Supply – Not required	
3	LVTTTL-I	Mod-Desel	Module De-select; When held low allows the module to respond to 2-wire serial interface commands	
4	LVTTTL-O	Interrupt	Interrupt (bar); Indicates presence of an important condition which can be read over the serial 2-wire interface	2
5	LVTTTL-I	TX_DIS	Transmitter Disable; Transmitter laser source turned off	
6		VCC5	+5 Power Supply	

7		GND	Module Ground	1
8		VCC3	+3.3V Power Supply	
9		VCC3	+3.3V Power Supply	
10	LVTTTL-I	SCL	Serial 2-wire interface clock	2
11	LVTTTL- I/O	SDA	Serial 2-wire interface data line	2
12	LVTTTL-O	Mod_Abs	Module Absent; Indicates module is not present. Grounded in the module.	2
13	LVTTTL-O	Mod_NR	Module Not Ready;	2
14	LVTTTL-O	RX_LOS	Receiver Loss of Signal indicator	2
15		GND	Module Ground	1
16		GND	Module Ground	1
17	CML-O	RD-	Receiver inverted data output	
18	CML-O	RD+	Receiver non-inverted data output	
19		GND	Module Ground	1
20		VCC2	+1.8V Power Supply	
21	LVTTTL-I	P_Down/RS T	Power Down; When high, places the module in the low power stand-by mode and on the falling edge of P_Down initiates a module reset Reset; The falling edge initiates a complete reset of the module including the 2-wire serial interface, equivalent to a power cycle.	
22		VCC2	+1.8V Power Supply	
23		GND	Module Ground	1
24	PECL-I	RefCLK+	Reference Clock non-inverted input, AC coupled on the host board	3
25	PECL-I	RefCLK-	Reference Clock inverted input, AC coupled on the host board	3
26		GND	Module Ground	1
27		GND	Module Ground	1
28	CML-I	TD-	Transmitter inverted data input	
29	CML-I	TD+	Transmitter non-inverted data input	
30		GND	Module Ground	1

Notes:

1. Module circuit ground is isolated from module chassis ground within the module.
2. Open collector; should be pulled up with 4.7k – 10k ohms on host board to a voltage between 3.15V and 3.6V.
3. Reference Clock input is not required.

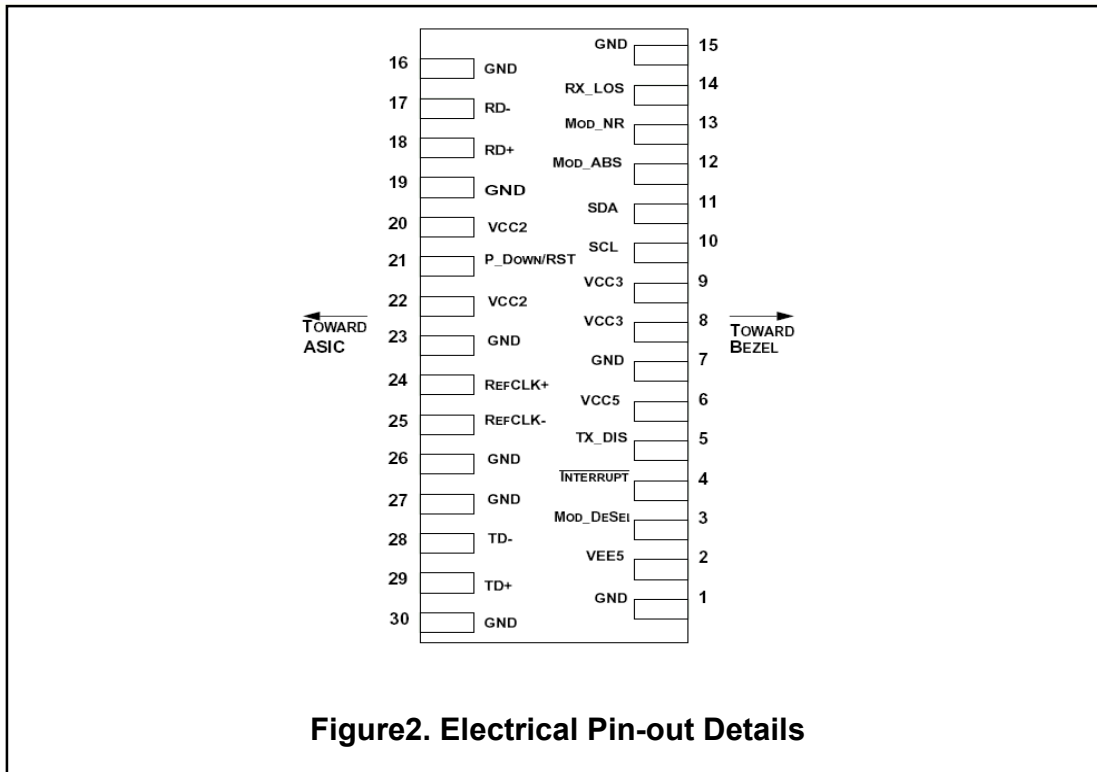

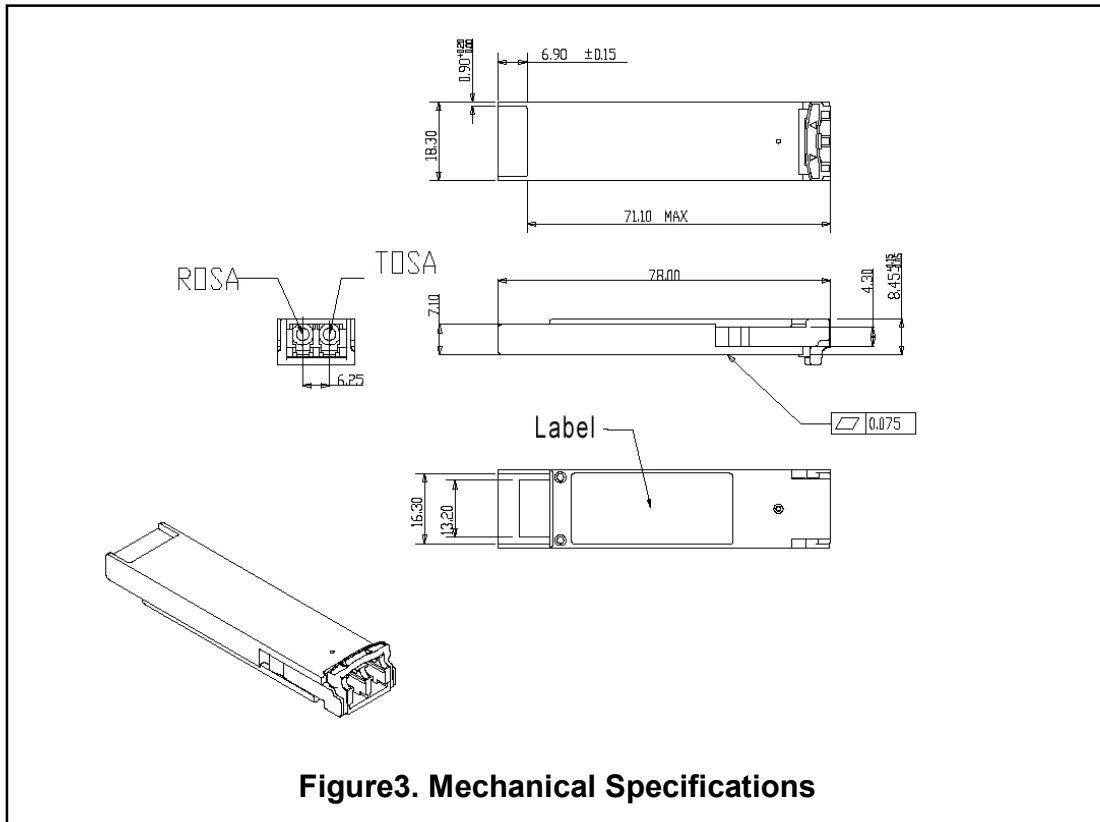

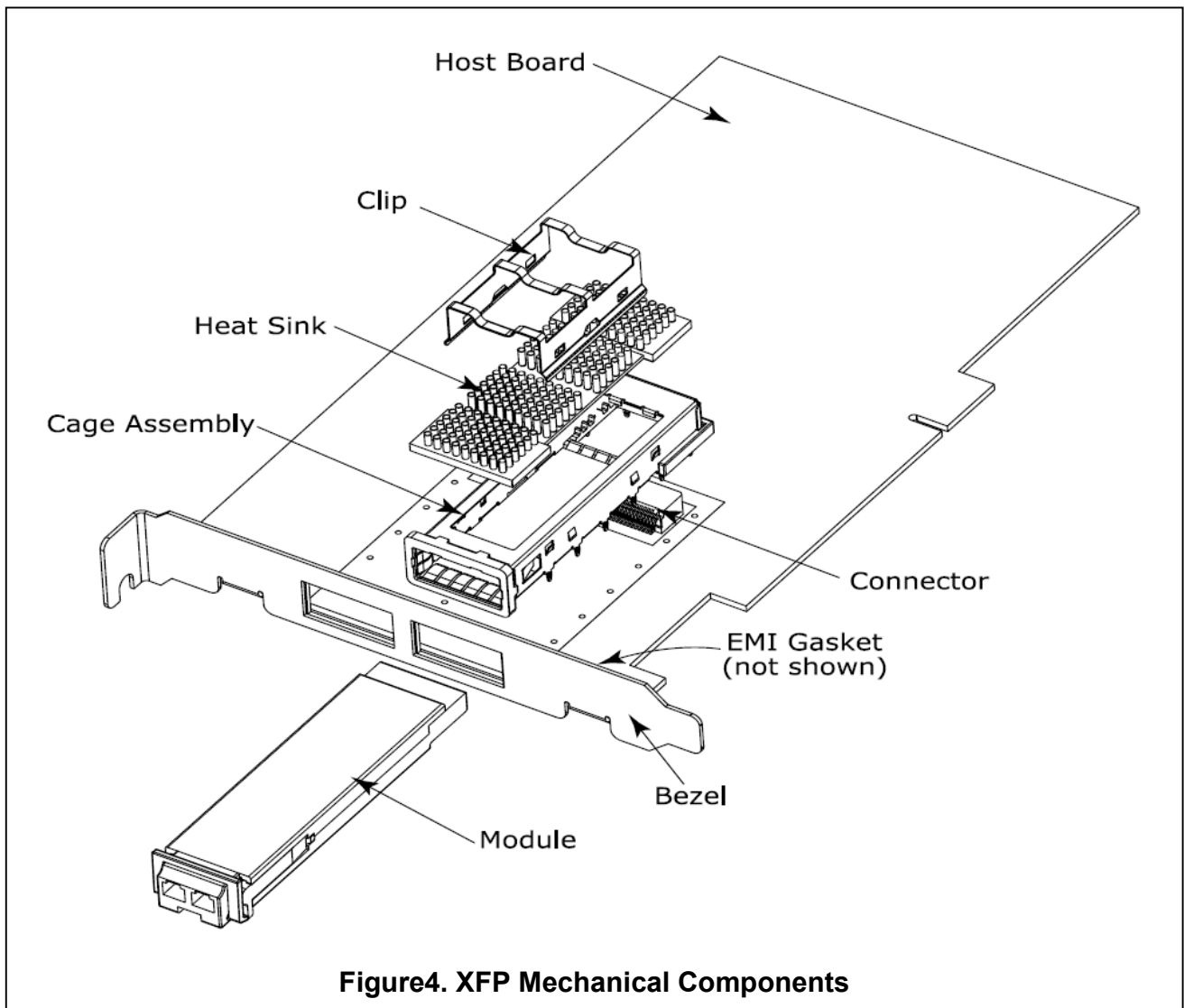

Figure4. XFP Mechanical Components

The mechanical components defined:

1. The module, clip and connector dimensions are constant for all applications. While the bezel, cage assembly, EMI gasket and heat sink can be designed and/or adjusted for the individual application.
2. The relatively small form factor of the XFP module combined with an adaptable heatsink option allows host system design optimization of module location, heatsink shape/dimension/fins design, and airflow control. The module can be inserted and removed from the cage with the heat sink and clip attached.

Regulatory Compliance

Empowerfiber XFP transceiver is designed to be Class I Laser safety compliant and is certified per the following standards:

Feature	Agency	Standard	Certificate / Comments
Laser Safety	FDA	CDRH 21 CFR 1040 and Laser Notice No. 50	1120288-000
Product Safety	UL	UL and CUL EN60950-2:2007	E347511
Environmental protection	SGS	RoHS Directive 2002/95/EC	GZ1001008706/CHEM
EMC	WALTEK	EN 55022:2006+A1:2007 EN 55024:1998+A1+A2:2003 -	WT10093768-D-E-E

Ordering information

Part Number	Product Description
EXD-XX192-04C	XX= ITU Grid 21~60, 10Gbps, DWDM XFP 40km, -5°C ~ +70°C

Important Notice

Performance figures, data and any illustrative material provided in this data sheet are typical and must be specifically confirmed in writing by empowerfiber before they become applicable to any particular order or contract. In accordance with the empowerfiber policy of continuous improvement specifications may change without notice.

The publication of information in this data sheet does not imply freedom from patent or other protective rights of empowerfiber or others. Further details are available from any empowerfiber sales representative.

E-mail: sales@empowerfiber.com

Web : <http://www.empowerfiber.com>